

UNIT 1 HIGHWAY ENGINEERING



Significance of highway planning

Wide Geographical Coverage provided by roads:

Roads can be constructed to penetrate the interior of any region and to connect remote villages. The advantage becomes particularly evident when planning the communication system in hilly regions and sparsely populated areas.

Low Capital investment:

Roads can be constructed at comparatively lower initial cost than railways. The cost of roads varies with specifications, but even the best road is cheaper than a railway line.

Quick and assured deliveries:

Time is great value for a wide range of articles; including both perishables and high value is manufactured products. Road transport by its quick deliveries reduces the need for larger inventories and locking up of working capital a great cost.

Flexibility:

Road transport offers a flexible service, free from fixed schedules. Any number of trucks or buses can be pressed into service quickly to meet sudden demand or withdrawn. Such a flexibility is absent in railways, which operate generally according to fixed schedules.

Door-to-door services:

Road transport offers door-to-door service, free from transshipments from origin to destination. Railways on the other hand have to depend upon road transport for picking up loads and making deliveries.

Simpler packaging:

Road transport permits simpler packaging and crating for the protection of goods against breakage.

Personalized service:

A personal touch is generally present in road transport. The customer is given individualized attention in various matters.

Employment potential:

Road transport has a high employment potential. This is an important factor in a country with a large and employment problem.

Personalized travel:

Travel by private car or motorized two wheeler or even a cycle, satisfies personal pleasures. This is one of the main reasons for the popularity of personalized travel mode in the developed countries.

Short hauls:

For short hauls transport is there only economical means if a major project is to be constructed and is the construction materials have to be transported through short distances one turns only to road transport.

Safety:

One of the serious advantages of road transport is its poor record of safety. Road accidents have become a serious menace, claiming enormous economic loss to the nation.

Environmental pollution:

Road transport has been one of the major causes for environmental pollution, noise fumes, vibration, loss of aesthetics, ribbon development these are the some ill effects.

Road transport has caused parking problem of serious proportions in city streets.

Long hauls:

It has been found that most commodity movements are cheaper by road for short hauls up to 300-350 kms, but beyond this range, the cost advantage lies with the railways.

Energy:

Road transport consumes greater energy per passenger km and tone km than railways.



History of road development in India

Roads in India perform a variety of roles in achieving speedy economic development. Some of the important aspects are discussed below:

Connection to villages

India is a country having 590,000 villages, scattered into small habitations and often located in the extreme interior. Thus social uplift, health and education of the village population is aided by roads.

Communications in hilly terrain:

For the hill states located along the Himalayan range, communication facility is possible only by roads because of the steep terrain involved.

Strategic importance:

The defense of the northern, north-eastern and western borders of the country is dependent to a large extent on the road system.

Helps agricultural development:

Roads have fostered quicker agricultural development facilitating movement of modern inputs such as fertilizers and high yielding seeds.

Helps dairy development:

Since the cattle wealth of the nation is concentrated in innumerable villages and small habitations, the collection and processing of surplus milk only because of roads.

Forestry development:

The forest wealth of the country is being exploited mainly because of the roads which penetrate in to the thick jungles.

Fisheries Development:

The Development of the fisheries along the coast line has been rendered possible because of the construction of link roads leading to the coast.

Tourism Development:

Some of the ancient monuments, religious places, natural parks and sanctuaries are accessible only roads. Tourism, both domestic and international, has been greatly aided by roads serving such as places of interest.

Employment:

As already stated, roads and road transport provide employment to a large number of people in the country. Since road construction involves labour intensive techniques in India, the large unemployed labor force gets gainful employment.

Famine and flood relief:

Roads have helped operations pertaining to flood and famine relief. The affected people are frequently employed on road construction to build durable assets.

Administrative convenience:

Roads have helped the effective administration of this large country. Maintenance of law and order and dispensation of justice have been aided by roads. National integration and cohesion have been brought about by roads which traverse the length and breadth of the country and which link people from different parts together.

Tresaguet construction:

- Pierre Tresaguet (1716-1796) developed an improved method of construction in France by the year 1764. The main feature of his proposal was that the thickness of construction need be only in the order of 30 cm.
- Tresaguet was the inspector General of roads in France from 1775 to 1785. So his method of construction was implemented in that country in 1775.
- The typical cross section of Tresaguet's road construction is given in fig. and the construction steps may be enumerated as below.

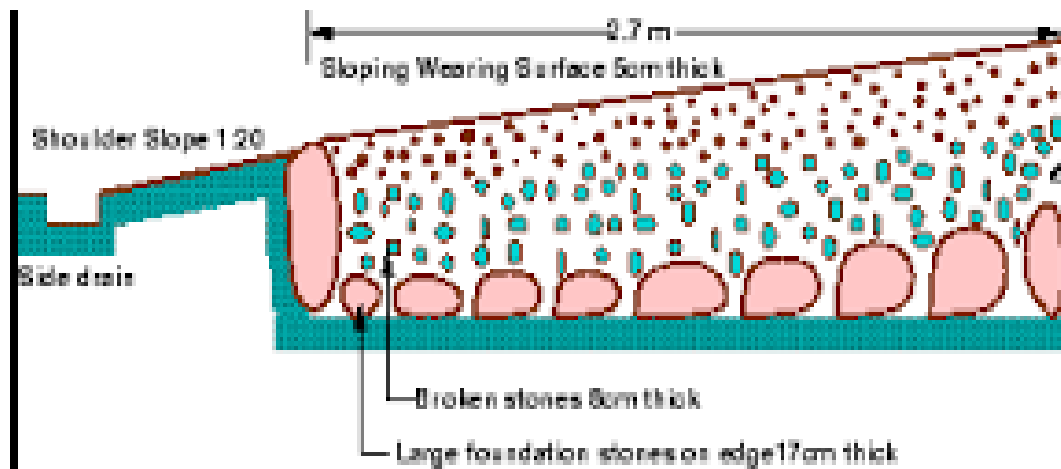

- The sub grade was prepared and layers of large foundation stones were laid on edge by hand. At the two edges of the pavement large stones were embedded edge wise to serve as submerged Krebs stones.
- The corners of the heavy foundation stones were hammered and then the interstices filled with smaller stones.
- The top-wearing course was made of smaller stones and compacted to a thickness of about 5 cm at the edges and gradually increased towards the center.
- The shoulders were also provides cross slope to drain the surface water to the side drain.

Macadam Construction

John Macadam put forward an entirely new method of road construction as compared to all the previous methods. A typical cross section of Macadam construction:

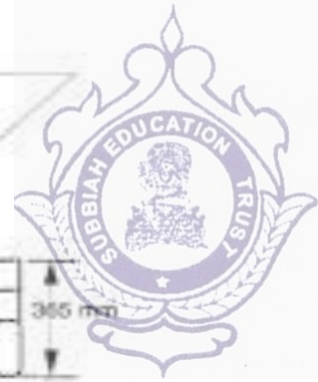
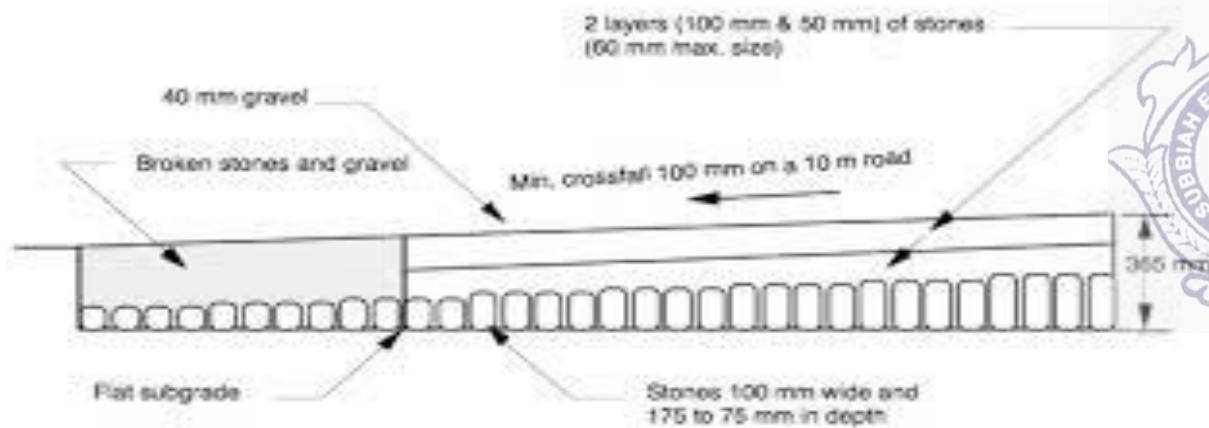

- i) The importance of sub grade drainage and compaction were recognized and the sub grade was compacted and was prepared with a cross slope of 1 in 36.
- ii) Macadam was the first person to suggest the heavy foundation stones are not at all necessary to be placed at the bottom layer of construction.
- iii) Though the total thickness of construction was less than previous methods. This technique could serve the purpose in a better way.
- iv) The size of broken stones for the top layer was decided based on the stability under animal drawn vehicles.

Macadam's method is the first method based on scientific thinking

The construction steps are:

- i) Sub grade is compacted and prepared with a cross slope of 1 in 36 up to a desired width.
- ii) Broken stones of a strong variety, all passing through 5 cm size sieve were compacted to a uniform thickness of 10cm.
- iii) The second layer of strong broken stones of size 3.75 cm was compacted to thickness of 10 cm.
- iv) The top layer consisted of stones of size less than 2 cm compacted to a thickness of about 5 cm. The cross slope of pavement surface was also 1 in 36.

Classification of roads

Road classification

The roads can be classified in many ways. The classification based on speed and accessibility is the most generic one. Note that as the accessibility of road increases, the speed reduces. Accordingly, the roads can be classified as follows in the order of increased accessibility and reduced speeds.

- **Freeways:** Freeways are access-controlled divided highways. Most freeways are four lanes, two lanes each direction, but many freeways widen to incorporate more lanes as they enter urban areas. Access is controlled through the use of interchanges, and the type of interchange depends upon the kind of intersecting road way (rural roads, another freeway etc.)
- **Expressways:** They are superior type of highways and are designed for high

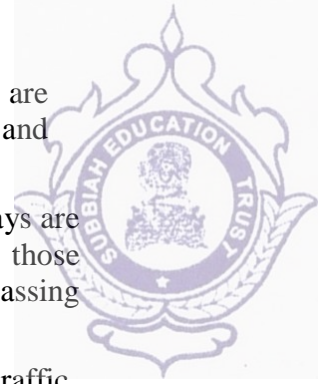

- speeds (120 km/hr is common), high traffic volume and safety. They are generally provided with grade separations at intersections. Parking, loading and unloading of goods and pedestrian traffic is not allowed on expressways.
- **Highways:** They represent the superior type of roads in the country. Highways are of two types - rural highways and urban highways. Rural highways are those passing through rural areas (villages) and urban highways are those passing through large cities and towns, ie. urban areas.
 - **Arterials:** It is a general term denoting a street primarily meant for through traffic usually on a continuous route. They are generally divided highways with fully or partially controlled access. Parking, loading and unloading activities are usually restricted and regulated. Pedestrians are allowed to cross only at intersections/designated pedestrian crossings.
 - **Local streets:** A local street is the one which is primarily intended for access to residence, business or abutting property. It does not normally carry large volume of traffic and also it allows unrestricted parking and pedestrian movements.
 - **Collector streets:** These are streets intended for collecting and distributing traffic to and from local streets and also for providing access to arterial streets. Normally full access is provided on these streets . There are few parking restrictions except during peak hours.



Figure 1: Speed vs accessibility



Design speed

Design speed is the single most important factor that affects the geometric design. It directly affects the sight distance, horizontal curve, and the length of vertical curves. Since the speed of vehicles vary with driver, terrain etc, a design speed is adopted for all the geometric design.

Design speed is defined as the highest continuous speed at which individual vehicles can travel with safety on the highway when weather conditions are conducive. Design speed is different from the legal speed limit which is the speed limit imposed to curb a common tendency of drivers to travel beyond an accepted safe speed. Design speed is also different from the desired speed which is the maximum speed at which a driver would travel when unconstrained by either traffic or local geometry.

Since there are wide variations in the speed adopted by different drivers, and by different types of vehicles, design speed should be selected such that it satisfy nearly all drivers. At the same time, a higher design speed has cascading effect in other geometric designs and thereby cost escalation. Therefore, an 85th percentile design speed is normally adopted. This speed is defined as that speed which is greater than the speed of 85% of drivers. In some countries this is as high as 95 to 98 percentile speed.

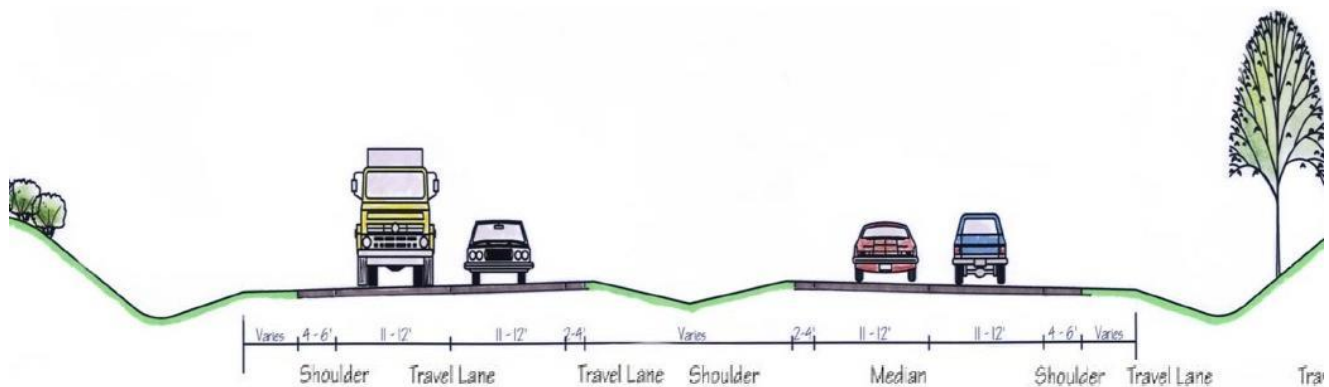

Four Lane Divided Roadway

Topography

The next important factor that affects the geometric design is the topography. It is easier to construct roads with required standards for a plain terrain. However, for a given design speed, the construction cost increases multiform with the gradient and the terrain. Therefore, geometric design standards are different for different terrain to keep the cost of construction and time of construction under control. This is characterized by sharper curves and steeper gradients.

Other factors

In addition to design speed and topography, there are various other factors that affect the geometric design and they are briefly discussed below:

- **Vehicle:** The dimensions, weight of the axle and operating characteristics of a vehicle influence the design aspects such as width of the pavement, radii of the curve, clearances, parking geometrics etc. A *design vehicle* which has standard weight, dimensions and operating characteristics are used to establish highway design controls to accommodate vehicles of a designated type.
- **Human:** The important human factors that influence geometric design are the , mental and psychological characteristics of the driver and pedestrians like the reaction time.
- **Traffic:** It will be uneconomical to design the road for peak traffic flow. Therefore a reasonable value of traffic volume is selected as the design hourly volume which is determined from the various traffic data collected. The geometric design is thus based on this design volume, capacity etc.
- **Environmental:** Factors like air pollution, noise pollution etc. should be given due consideration in the geometric design of roads.
- **Economy:** The design adopted should be economical as far as possible. It should match with the funds allotted for capital cost and maintenance cost.
- **Others:** Geometric design should be such that the aesthetics of the region is not affected.

Nagpur classification

In Nagpur road classification, all roads were classified into five categories as National highways, State highways, Major district roads, Other district roads and village roads.

National highways

- They are main highways running through the length and breadth of India connecting major ports , foreign highways, capitals of large states and large industrial and tourist centers including roads required for strategic movements.
- It was recommended by Jayakar committee that the National highways should be the frame on which the entire road communication should be based.
- All the national highways are assigned the respective numbers.
- For e.g. the highway connecting Delhi-Ambala-Amritsar is denoted as NH-1 (Delhi-Amritsar), where as a bifurcation of this highway beyond Full under to Srinagar and Uri is denoted as NH-1_A.
- They are constructed and maintained by CPWD.
- The total lengths of National highway in the country is 58,112 Kms, and constitute about 2% of total road networks of India and carry 40% of total traffic.

State highways

- They are the arterial roads of a state, connecting up with the national highways of adjacent states, district headquarters and important cities within the state
- They also serve as main arteries to and from district roads.
- Total length of all SH in the country is 1, 37,119 Kms.

Major district roads

- Important roads with in a district serving areas of production and markets , connecting those with each other or with the major highways.
- India has a total of 4, 70,000 Kms of MDR.

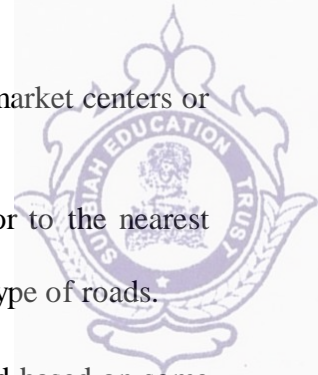

Other district roads

- Roads serving rural areas of production and providing them with outlet to market centers or other important roads like MDR or SH.

Village roads

- They are roads connecting villages or group of villages with each other or to the nearest road of a higher category like ODR or MDR.
- India has 26,50,000 kms of ODR+VR out of the total 33,15,231 kms of all type of roads.

Roads classification criteria

Apart from the classification given by the different plans, roads were also classified based on some other criteria. They are given in detail below.

Based on usage

This classification is based on whether the roads can be used during different seasons of the year.

- All-weather roads: Those roads which are negotiable during all weathers, except at major river crossings where interruption of traffic is permissible up to a certain extent are called all weather roads.
- Fair-weather roads: Roads which are negotiable only during fair weather are called fair weather roads.

Based on carriage way

This classification is based on the type of the carriage way or the road pavement.

- Paved roads with hards surface : If they are provided with a hard pavement course such roads are called paved roads.(eg: stones, Water bound macadam (WBM), Bituminous macadam (BM), concrete roads)
- Unpaved roads: Roads which are not provided with a hard course of atleast a WBM layer they is called unpaved roads. Thus earth and gravel roads come under this category.

Alignment

The position or the layout of the central line of the highway on the ground is called the alignment. Horizontal alignment includes straight and curved paths. Vertical alignment includes level and gradients. Alignment decision is important because a bad alignment will enhance the construction, maintenance and vehicle operating costs. Once an alignment is fixed and constructed, it is not easy to change it due to increase in cost of adjoining land and construction of costly structures by the roadside.

Requirements

The requirements of an ideal alignment are

- The alignment between two terminal stations should be short and as far as possible be straight, but due to some practical considerations deviations may be needed.
- The alignment should be easy to construct and maintain. It should be easy for the operation of vehicles. So to the maximum extend easy gradients and curves should be provided.
- It should be safe both from the construction and operating point of view especially at slopes, embankments, and cutting. It should have safe geometric features.
- The alignment should be economical and it can be considered so only when the initial cost, maintenance cost, and operating cost are minimum.

Factors controlling alignment

We have seen the requirements of an alignment. But it is not always possible to satisfy all these requirements. Hence we have to make a judicial choice considering all the factors.

The various factors that control the alignment are as follows:

- **Obligatory points:** These are the control points governing the highway alignment. These points are classified into two categories. Points through which it should pass and points through which it should not pass. Some of the examples are:
 - **Bridge site:** The bridge can be located only where the river has straight and permanent path and also where the abutment and pier can be strongly founded. The road approach to the bridge should not be curved and skew crossing should be avoided as possible. Thus to locate a bridge the highway alignment may be changed.
 - **Mountain:** While the alignment passes through a mountain, the various alternatives are to either construct a tunnel or to go round the hills. The suitability of the alternative depends on factors like topography, site conditions and construction and operation cost.
 - **Intermediate town:** The alignment may be slightly deviated to connect an intermediate town or village nearby.

These were some of the obligatory points through which the alignment should pass. Coming to the second category, that is the points through which the alignment should not pass are:

- **Religious places:** These have been protected by the law from being acquired for any purpose. Therefore, these points should be avoided while aligning.
- **Very costly structures:** Acquiring such structures means heavy compensation which would result in an increase in initial cost. So the alignment may be deviated not to pass through that point.
- **Lakes/ponds etc:** The presence of a lake or pond on the alignment path would also necessitate deviation of the alignment.

Traffic: The alignment should suit the traffic requirements. Based on the origin-destination data of the area, the desire lines should be drawn. The new alignment should be drawn keeping in view the desire lines, traffic flow pattern etc. **Geometric design:** Geometric design factors such as gradient, radius of curve, sight distance etc. also govern the alignment of the highway. To keep the radius of curve minimum, it may be required to change the alignment. The alignments should be finalized such that the obstructions to visibility do not restrict the minimum requirements of sight distance. The design standards vary with the class of road and the terrain and accordingly the highway should be aligned. **Economy:** The alignment finalized should be economical. All the three costs i.e. construction, maintenance, and operating cost should be minimum. The construction cost can be decreased much if it is possible to maintain a balance between cutting and filling. Also try to avoid very high embankments and very deep cuttings as the construction cost will be very higher in these cases.

Road ecology

The features of the cross-section of the pavement influences the life of the pavement as



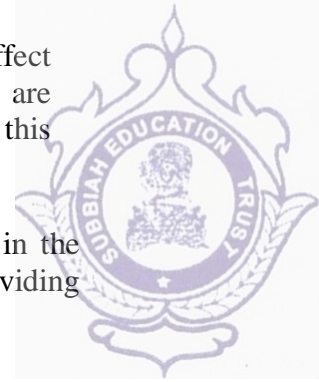

well as the riding comfort and safety. Of these, pavement surface characteristics affect both of these. Camber, kerbs, and geometry of various cross-sectional elements are important aspects to be considered in this regard. They are explained briefly in this chapter.

Camber

Camber or cant is the cross slope provided to raise middle of the road surface in the transverse direction to drain off rain water from road surface. The objectives of providing camber are:

- Surface protection especially for gravel and bituminous roads
- Sub-grade protection by proper drainage
- Quick drying of pavement which in turn increases safety

Too steep slope is undesirable for it will erode the surface. Camber is measured in *1 in n* or *n%* (Eg. 1 in 50 or 2%) and the value depends on the type of pavement surface. The value suggested by IRC for various categories of pavement is given in Table 1. The common types of camber are parabolic, straight, or combination of them (Figure 1)

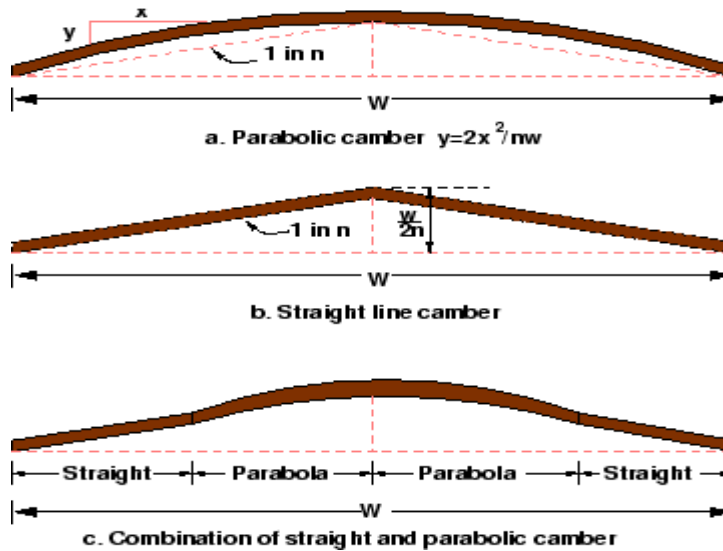

Figure 1: Different types of camber

Table 1: IRC Values for camber		
Surface type	Heavy rain	Light rain
Concrete/Bituminous	2 %	1.7 %
Gravel/WBM	3 %	2.5 %
Earthen	4 %	3.0 %



Engineering surveys for alignment

The stages of the engineering surveys are:

- a) Map study.
- b) Reconnaissance.
- c) Preliminary surveys.
- d) Final location and detailed surveys.

Map study: -

*) In the topographic map, to suggest the likely routes of roads. In India topographic maps are available from the survey of India with 15 or 30-meter contour intervals.

*) The main feature like rivers, hills, and valleys etc. The probable alignment can be located on the map from the following details available on the map.

- Alignment avoiding valleys, ponds or lakes
- When the road has to cross a row of hills, possibility crossing through a mountain pass.
- Approximate location of bridge site for crossing rivers, avoiding bend of the river.
- When a road is to be connected between two stations one of the top and the other on the foot of the hill then alternate routes can be suggested keeping in view the permissible alignment.
- Suppose the scale of the contour map is known, and then the contour intervals it is possible to decide the length of road required between two consecutive contours keeping the gradient within allowable limits.
- In the fig. Let A and B be two stations to be connected by road. AB is the shortest route (Straight line) APQB is a steep route in which the gradient positively exceeds 1 in 20 as the distance between the contour intervals is only about 200 meter
- APLMNB is a route with an approximate slope of 1 in 20 whereas APEFGB is an alternate alignment with the same gradient.
- Thus the map study also is possible to drop a certain route in view of any unavoidable obstructions (or) undesirable ground enroute.

Reconnaissance:-

The second stage of surveys for highway location is the reconnaissance to examine the general character of the area for deciding the most feasible routes for detailed studies.

Some of the details to be collected during reconnaissance are given below:

- Valleys, ponds, lakes, marshy, land, ridge, hills, permanent structures and other obstructions along the route, which are not available in the map.
- Approximate values of gradient, length of gradients and radius of curves of alternate alignments.
- Number and types of cross drainage structures maximum flood level and natural groundwater level along the probable routes.
- Soil type along the routes from field identification tests and observation of geological features.
- Sources of construction materials water and location of stone quarries.
- When the road passes through hilly or mountainous terrain, additional data regarding the geological formation types of rocks, dip of strata, seepage flow etc.

Preliminary survey: -

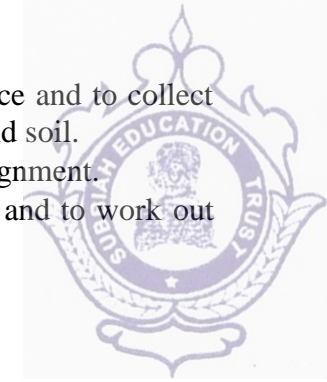

The main objectives of the preliminary surveys are:

- To survey the various alternate alignments proposed after the reconnaissance and to collect all the necessary physical information and details of topography, drainage and soil.
- To compare the different proposals in view of the requirements of a good alignment.
- To estimate quantity of earthwork materials and other construction aspects and to work out the cost of alternate proposals.
- To finalize the best alignment from all considerations.

The procedure of the conventional methods of preliminary surveys the given steps:

Primary survey: -

For alternate alignments either secondary traverses (or) independent primary traverses may be necessary.

Topographical features: -

All geographical and other man made features along the traverse and for a certain width on either side surveyed and plotted.

Leveling work: -

Levelling work is also carried out side by side to give the centerline profiles and typical cross sections. The leveling work in the preliminary survey is kept to a minimum just sufficient to obtain the approximate earthwork in the alternate alignments.

Drainage studies: -

Drainage investigations and hydrological data are collected so as to estimate the type, number and approximate size of cross and drainage structures.

Soil survey: -

The soil survey conducted at this stage helps to working out details of earthwork, slopes, suitability of materials, subsoil and surface drainage requirements and pavement type and the approximate thickness requirements.

Material survey: -

The survey for naturally occurring materials like stone aggregates, soft aggregates etc and identification of suitable quarries should be made.

Traffic survey: -

Traffic surveys conducted in the region from basis for deciding the number of traffic lanes and roadway width, pavement design and economic analysis of highway project.

Locations and functions

Final location and detailed survey: -

The alignment finalized at the design office after the preliminary survey is to be first located on the field by establishing the centerline. The detailed survey should be carried out for collecting the information technology for the preparation of plans and construction details.

Location: -

- The centerline of the road finalized in the drawings to be translated on the ground during the location survey.
- Major and minor control points are established on the ground and center pegs are driven, checking the geometric design, requirements.

Detailed survey: -

-

Levelling work should be taken at all staked points. Levelling work is of great importance as the vertical alignment.

- A detailed soil survey is carried out to enable drawing of the soil profile.
- The data during the detailed survey should be elaborate and complete for preparing detailed plans, design and estimates of the project.

Soil suitability analysis

The methodology for locating appropriate sites for each land use activity is guided by the intent to minimize the possible adverse effects of development on the environment and on existing communities, and to emphasize the positive impacts of such development, by locating them in a most suitable location.

This is achieved by examining a number of individual criteria, assigning them relative levels of importance as a whole, and using a mathematical resultant model to identify the most suitable location.

By adopting this site suitability method, it is possible to systematically identify the criteria considered, clearly document the relative importance of one criterion over another, analyze the net outcome using a Geographic Information System, and then possibly revisit the mathematical relationships in this “decision model” .

By revising the relative importance to identified criteria based upon the particular land use under consideration, it is possible to generate “suitability maps” for each individual land use, and then generate a final composite land use that is based on a best possible collective suitability of multiple land uses.

To achieve this, all the criteria are assigned a “rank” denoting their relative levels of importance within the suitability study. These ranks are assigned as numeric values ranging from 1 to 10, with 1 reflecting a low level of importance and 10 reflecting a high level of importance. For example, within the criteria of road networks, national highways would have a different level of influence on the suitability for a particular land use, as compared with local roads. Further, the distance from each of these features would further modify the relative suitability of a land use based on the proximity to a particular type of road.

Criteria for Site Suitability Analysis:

The decision criteria for site selection are examined for assigning relative ranks and individual feature weights based on the land use type for which suitability is being examined. For benefit of analysis, the criteria under consideration in this paper activity are organized as:

Critical Criteria: Criteria that will be very significant in the site selection of the identified land use and will act as key drivers in the selection of the geographic location. These criteria can be clustered into a single decision model and the outcome collectively reviewed. These criteria have a strong influence in the final suitability.

Additional Criteria: Criteria that will have to be examined one at a time to carefully assess its relationship with the proposed land use activity. These criteria have a positive influence in the final suitability.

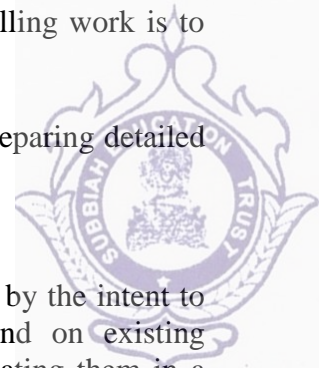

Constrained Criteria: These criteria impose strong negative opportunities in the selection of areas for the identified land use. Consequently, they inform of us of where the particular land use under consideration should not be located. These criteria serve to limit or exclude areas from the final suitability.

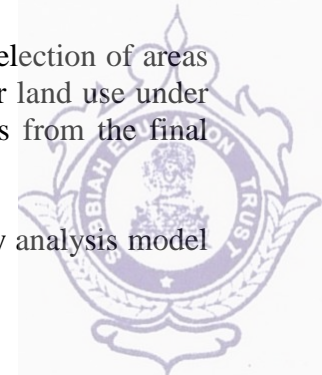

GIS Site Suitability Analysis Model: We were developed a tourism site suitability analysis model in ArcGIS - 9.3.1, which is shown in Figure -

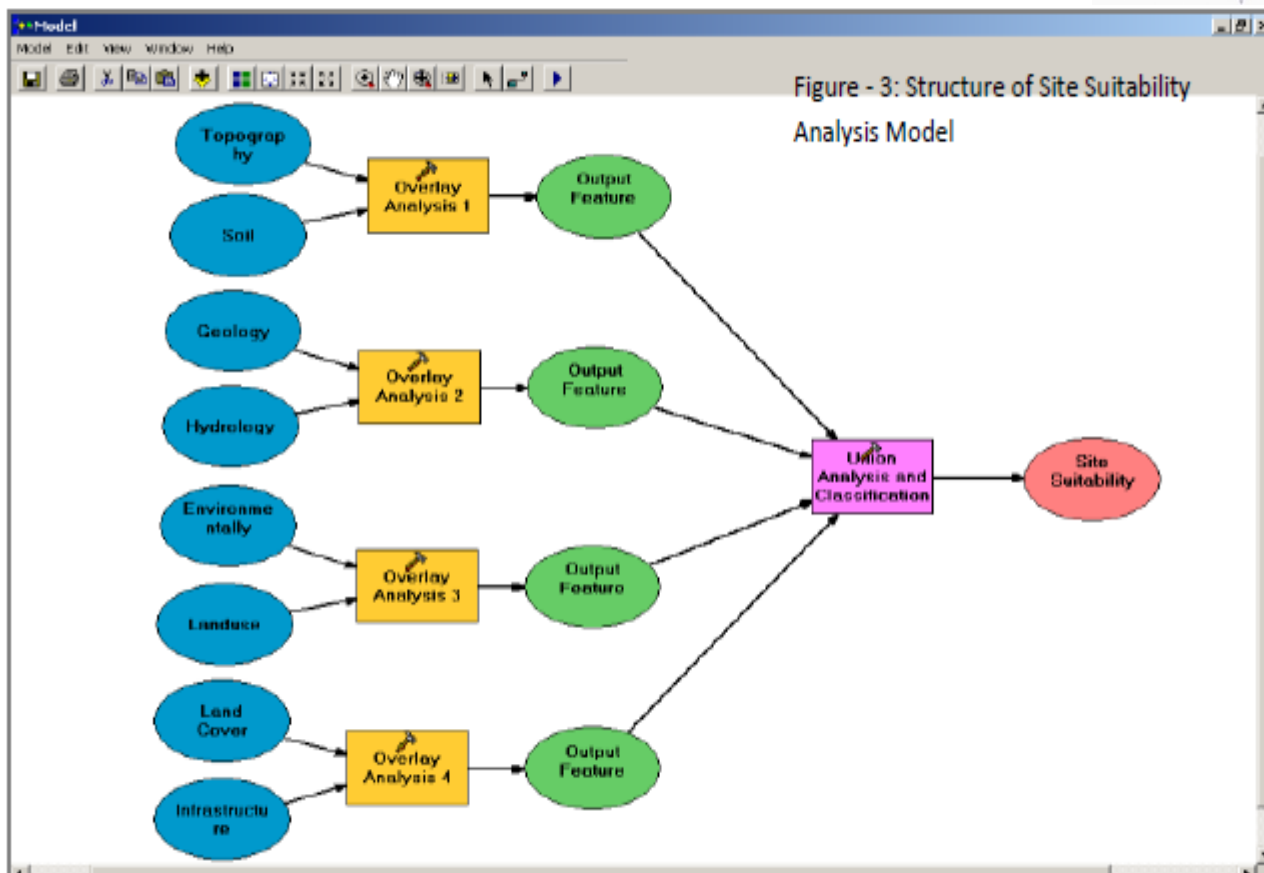

UNIT 2 DESIGN OF HIGHWAY ELEMENTS



Typical cross section of urban and rural roads

A cross section is a vertical plane (slice) taken at right angles to the road control line showing the various elements that make up the roads structure. It is normally viewed in the direction of increasing chainage.

The width of a roadway is an important design consideration to ensure that it is appropriately sized to serve its function. Because of the diversity within the County, two major roadway categories have been established: 1. Rural Road Standards; 2. Urban Road Standards. Urban Road Standards will serve those areas which tend to be more developed and need to provide for multiple users (bicyclists, pedestrians, parallel parking, etc.) whereas, many rural roads will primarily serve only vehicular traffic.

Cross sections are created to provide a visual guide depicting the initial, interim, and ultimate phase cross sections for these road classifications. The typical sections illustrated in the following pages are recommendations tied to transportation planning aspects, such as right-of-way, lineage, sidewalk width, etc. Threshold daily traffic can be used as a guide for a starting point when determining which cross section is most applicable.

1. Rural Road Standards

The rural roadways will not typically require curb and gutter or sidewalk, although the County may require either or both in unique circumstances. Widths of lanes and shoulders will vary depending upon the specific classification and the potential traffic volume which the roadway may carry. Roads carrying fewer than 200 vehicles per day need not be paved or treated for dust control. The need for paved shoulders is also dependent upon the level of traffic and safety.

Final design and construction details will be determined by the Public Works Department. Final Design and construction criteria taken into consideration may include, but are not limited to; use of the roadway, density of development, topographical characteristics and nearby development. For construction in which only a portion of the ultimate cross-section is intended to be completed, the partial design will need to allow for the eventual widening to the ultimate cross-section. The design for the partial or interim cross-section roadway will need to incorporate ultimate design information to ensure that the first phase of roadway construction is appropriate and would not need to be removed at a future date when the full width cross-section is completed.

2. Urban Road Standards

Three roadway classifications are identified for those areas that are associated with the community's urban growth areas. They include arterial, collector, and local street classifications. Transportation Plan shows the key elements of the urban road standards. Urban road standards will include 12-foot lanes, sidewalk and curb & gutter; arterials and collectors will also include a striped bike lane. Turn lanes may be necessary as determined by the County. Since almost all of the municipalities have different right-of-way cross sections adopted for their community, it makes it very difficult for the County to match them all. Therefore, the philosophy was to encourage a baseline amount of right-of-way reservation that could ensure the adjacent community enough area for coordination of future roadway improvements, until such time the road.

TYPICAL CROSS SECTIONS - RURAL ARTERIAL

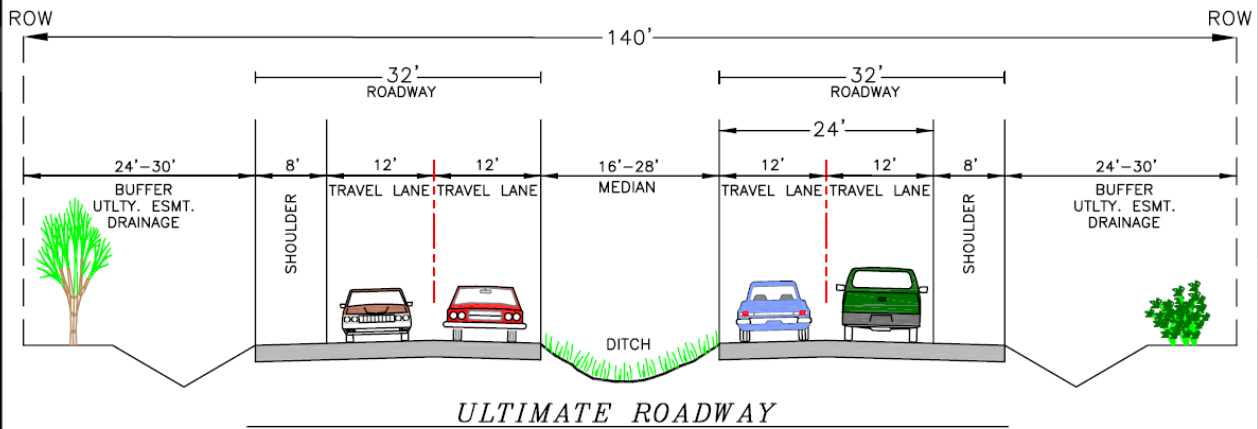
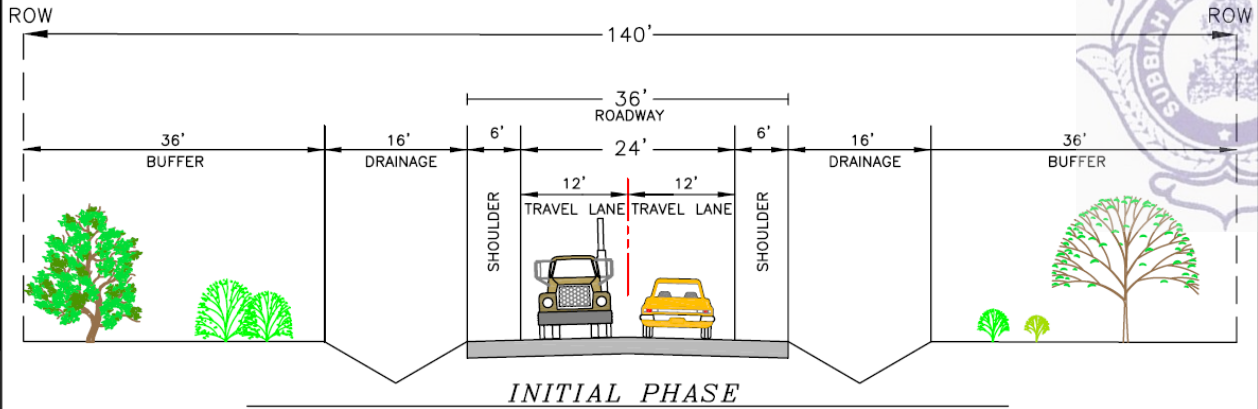
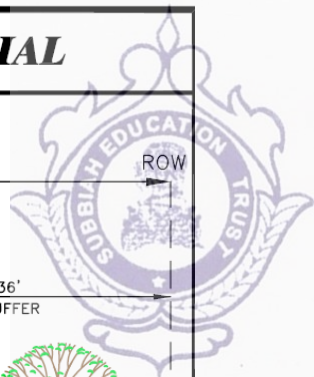

INTERSECTION

TRAVEL LANES W/TURNS

4'± DIVIDE BETWEEN OPPOSITE BOUND LANES

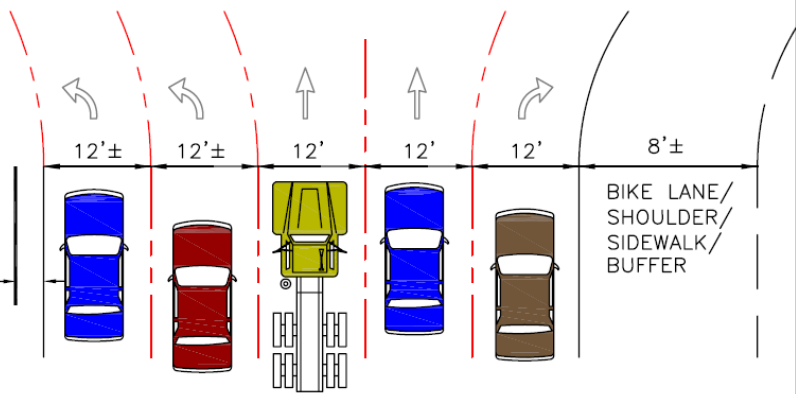

TYPICAL CROSS SECTIONS - URBAN COLLECTOR

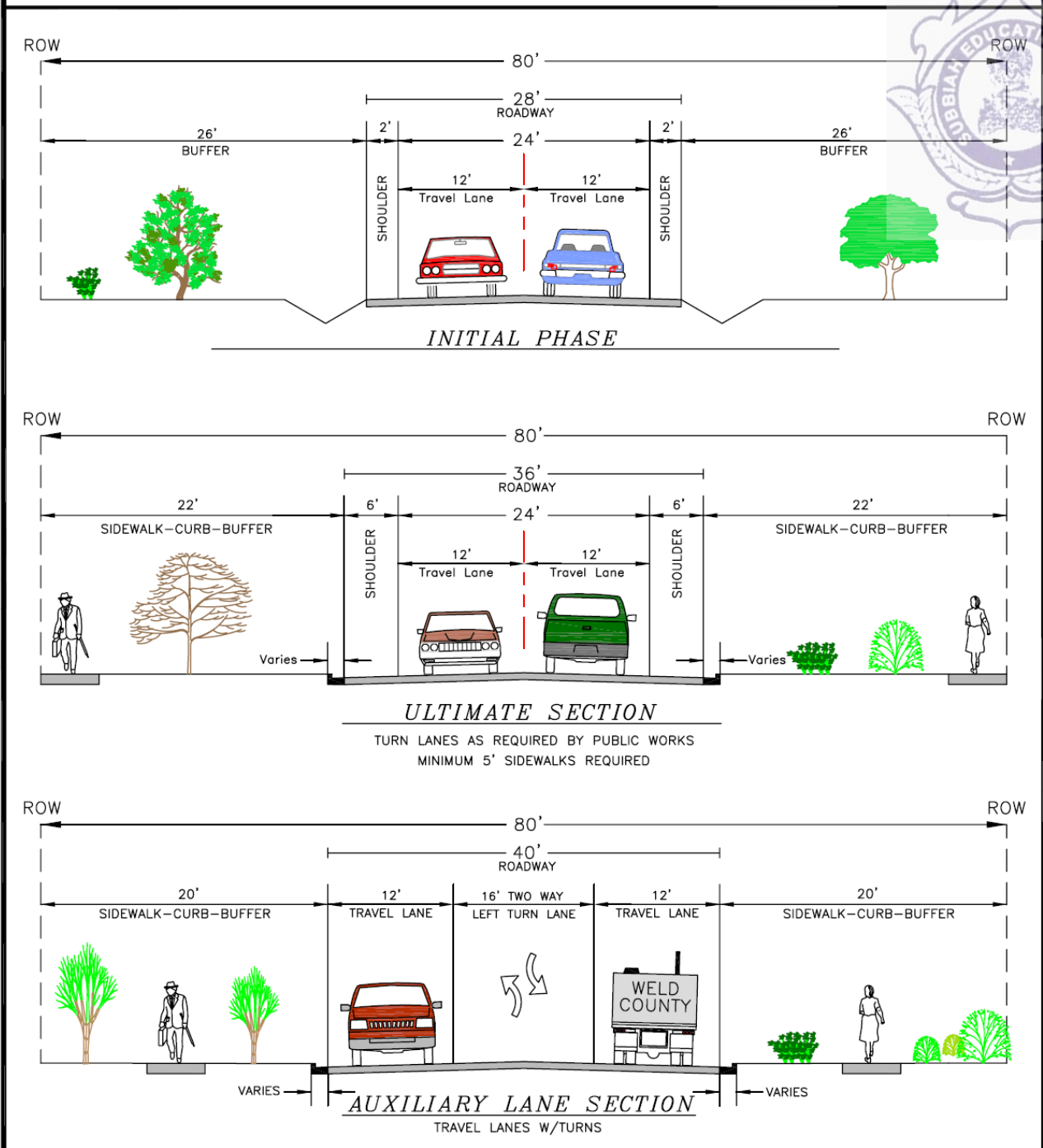
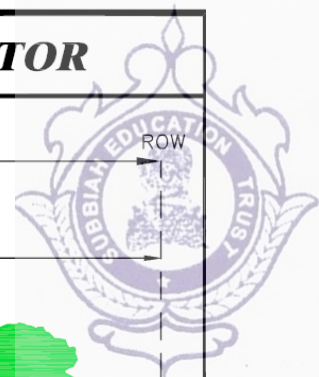

Cross sectional elements

Kerbs

Kerbs indicate the boundary between the carriage way and the shoulder or islands or footpaths. Different types of kerbs are

Low or mountable kerbs: This type of kerbs is provided such that they encourage the traffic to remain in the through traffic lanes and also allow the driver to enter the shoulder area with little difficulty. The height of this kerb is about 10 cm above the pavement edge with a slope which allows the vehicle to climb easily. This is usually provided at medians and channelization schemes and also helps in longitudinal drainage.

- **Semi-barrier type kerbs:** When the pedestrian traffic is high, these kerbs are provided. Their height is 15 cm above the pavement edge. This type of kerb prevents encroachment of parking vehicles, but at acute emergency it is possible to drive over this kerb with some difficulty.
- **Barrier type kerbs:** They are designed to discourage vehicles from leaving the pavement. They are provided when there is considerable amount of pedestrian traffic. They are placed at a height of 20 cm above the pavement edge with a steep batter.
- **Submerged kerbs:** They are used in rural roads. The kerbs are provided at pavement edges between the pavement and shoulders. They provide lateral confinement and stability to the pavement.

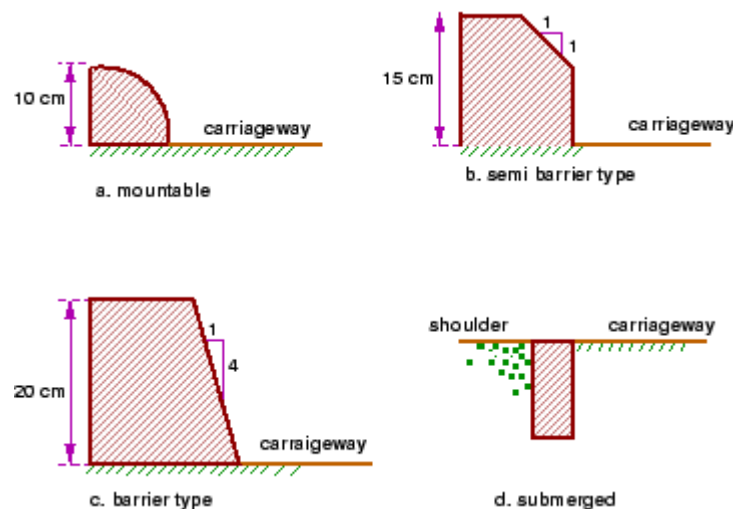

Figure 1: Different types of kerbs

Shoulders

Shoulders are provided along the road edge and are intended for accommodation of stopped vehicles, serve as an emergency lane for vehicles and provide lateral support for base and surface courses. The shoulder should be strong enough to bear the weight of a fully loaded truck even in wet conditions. The shoulder width should be adequate for giving working space around a stopped vehicle. It is desirable to have a width of 4.6 m for the shoulders. A minimum width of 2.5 m is recommended for 2-lane rural highways in India.

Parking lanes

Parking lanes are provided in urban lanes for side parking. Parallel parking is preferred because it is safe for the vehicles moving on the road. The parking lane should have a minimum of 3.0 m width in the case of parallel parking.

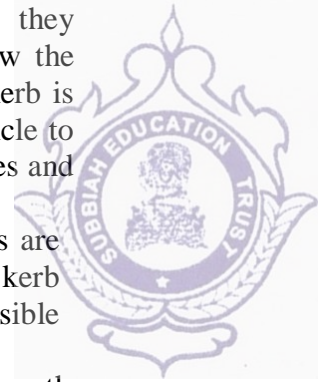

Bus-bays

Bus bays are provided by recessing the kerbs for bus stops. They are provided so that they do not obstruct the movement of vehicles in the carriage way. They should be at least 75 meters away from the intersection so that the traffic near the intersections is not affected by the bus-bay.

Service roads

Service roads or frontage roads give access to access controlled highways like freeways and expressways. They run parallel to the highway and will be usually isolated by a separator and access to the highway will be provided only at selected points. These roads are provided to avoid congestion in the expressways and also the speed of the traffic in those lanes is not reduced.

Drainage

The pavement surface should be absolutely impermeable to prevent seepage of water into the pavement layers. Further, both the geometry and texture of pavement surface should help in draining out the water from the surface in less time.

Footpath

Footpaths are exclusive right of way to pedestrians, especially in urban areas. They are provided for the safety of the pedestrians when both the pedestrian traffic and vehicular traffic is high. Minimum width is 1.5 meter and may be increased based on the traffic. The footpath should be either as smooth as the pavement or more smoother than that to induce the pedestrian to use the footpath.

Right of way

Right of way (ROW) or land width is the width of land acquired for the road, along its alignment. It should be adequate to accommodate all the cross-sectional elements of the highway and may reasonably provide for future development. To prevent ribbon development along highways, control lines and building lines may be provided. Control line is a line which represents the nearest limits of future uncontrolled building activity in relation to a road. Building line represents a line on either side of the road, between which and the road no building activity is permitted at all. The right of way width is governed by:

- Width of formation: It depends on the category of the highway and width of roadway and road margins.
- Height of embankment or depth of cutting: It is governed by the topography and the vertical alignment.
- Side slopes of embankment or cutting: It depends on the height of the slope, soil type etc.
- Drainage system and their size which depends on rainfall, topography etc.
- Sight distance considerations: On curves etc. there is restriction to the visibility on the inner side of the curve due to the presence of some obstructions like building structures etc.
- Reserve land for future widening: Some land has to be acquired in advance

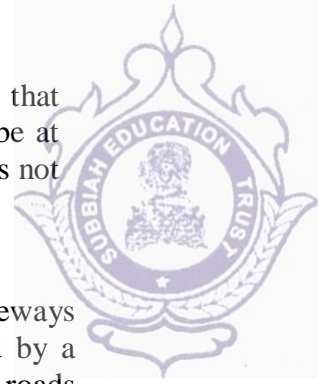
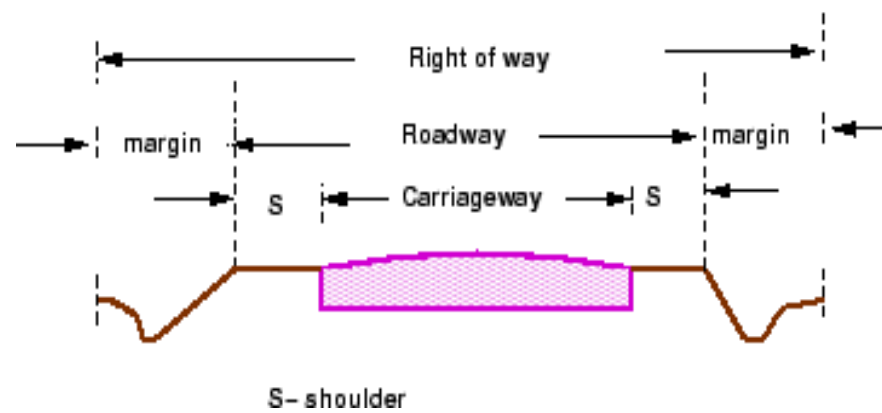



Table 1: right of way for open areas

Road classification	Roadway width in m	
	Plain and rolling terrain	Mountainous and steep terrain
Open areas		
NH/SH	45	24
MDR	25	18
ODR	15	15
VR	12	9
Built-up areas		
NH/SH	30	20
MDR	20	15
ODR	15	12
VR	10	9



km/hr

Table 2: Design speed in as per IRC (ruling and minimum)

Type	Plain	Rolling	Hilly	Steep
NS&SH	100-80	80-65	50-40	40-30
MDR	80-65	65-50	40-30	30-20
ODR	65-50	50-40	30-25	25-20
VR	50-40	40-35	25-20	25-20

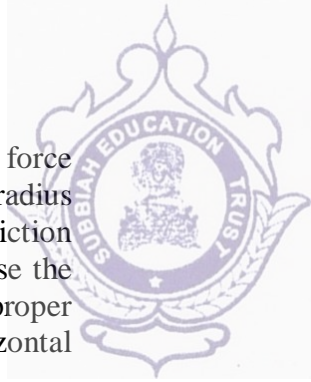

Horizontal curve

The presence of horizontal curve imparts centrifugal force which is a reactive force acting outward on a vehicle negotiating it. Centrifugal force depends on speed and radius of the horizontal curve and is counteracted to a certain extent by transverse friction between the tyre and pavement surface. On a curved road, this force tends to cause the vehicle to overrun or to slide outward from the centre of road curvature. For proper design of the curve, an understanding of the forces acting on a vehicle taking a horizontal curve is necessary. Various forces acting on the vehicle are illustrated in the figure 1.

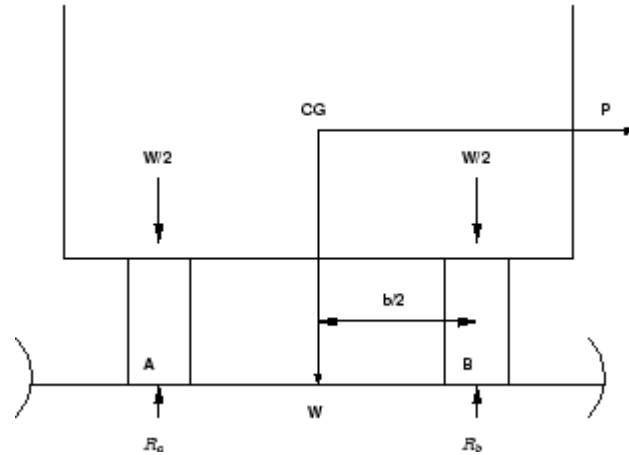

Figure 1: Effect of horizontal curve

They are the centrifugal force (P) acting outward, weight of the vehicle (W) acting downward, and the reaction of the ground on the wheels (R_A and R_B). The centrifugal force and the weight is assumed to be from the centre of gravity which is at h units above the ground. Let the wheel base be assumed as b units. The centrifugal force P in kg/m^2 is given by

$$P = \frac{Wv^2}{gR} \quad (1)$$

where W is the weight of the vehicle in kg , v is the speed of the vehicle in m/sec , g is the acceleration due to gravity in m/sec^2 and R is the radius of the curve in m .

The centrifugal ratio or the impact factor $\frac{P}{W}$ is given by:

$$\frac{P}{W} = \frac{v^2}{gR} \quad (1)$$

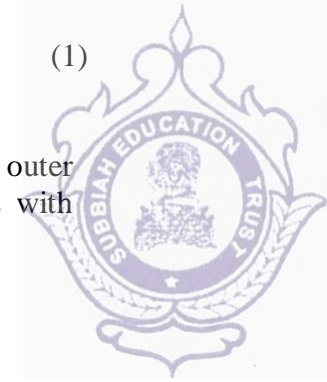

The centrifugal force has two effects: A tendency to overturn the vehicle about the outer wheels and a tendency for transverse skidding. Taking moments of the forces with respect to the outer wheel when the vehicle is just about to override,

$$Ph = W \frac{b}{2} \text{ or } \frac{P}{W} = \frac{b}{2h}$$

At the equilibrium over turning is possible when

$$\frac{v^2}{gR} = \frac{b}{2h}$$

and for safety the following condition must satisfy:

$$\frac{b}{2h} > \frac{v^2}{gR} \quad (2)$$

The second tendency of the vehicle is for transverse skidding. i.e. When the the centrifugal force P is greater than the maximum possible transverse skid resistance due to friction between the pavement surface and tyre. The transverse skid resistance (F) is given by:

$$\begin{aligned} F &= F_A + F_B \\ &= f(R_A + R_B) \\ &= fW \end{aligned}$$

where F_A and F_B is the fractional force at tyre A and B , R_A and R_B is the reaction at tyre A and B , f is the lateral coefficient of friction and W is the weight of the vehicle. This is counteracted by the centrifugal force (P), and equating:

$$P = fW \text{ or } \frac{P}{W} = f$$

At equilibrium, when skidding takes place (from equation 1)

$$\frac{P}{W} = f = \frac{v^2}{gR}$$

and for safety the following condition must satisfy:

$$f > \frac{v^2}{gR}$$

(3)

Equation 2 and 3 give the stable condition for design. If equation 2 is violated, the vehicle will overturn at the horizontal curve and if equation 3 is violated, the vehicle will skid at the horizontal

Curve Analysis of super-elevation

Super-elevation or cant or banking is the transverse slope provided at horizontal curve to counteract the centrifugal force, by raising the outer edge of the pavement with respect to the inner edge, throughout the length of the horizontal curve. When the outer edge is raised, a component of the curve weight will be complimented in counteracting the effect of centrifugal force. In order to find out how much this raising should be, the following analysis may be done. The forces acting on a vehicle while taking a horizontal curve with super elevation is shown in figure 1.

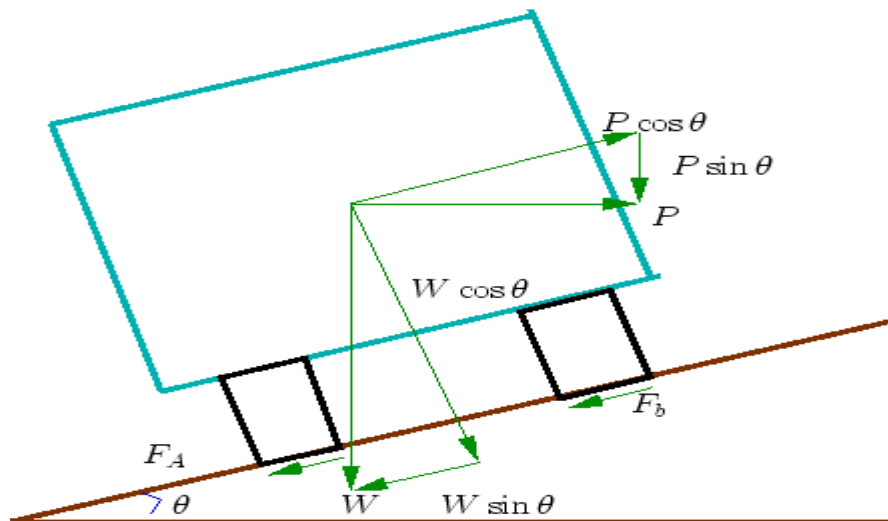

Figure 1: Analysis of super-elevation

Forces acting on a vehicle on horizontal curve of radius R m at a speed of v $\frac{m}{sec^2}$ are:

- P the centrifugal force acting horizontally out-wards through the center of gravity,
- W the weight of the vehicle acting down-wards through the center of gravity, and
- F the friction force between the wheels and the pavement, along the surface inward.

At equilibrium, by resolving the forces parallel to the surface of the pavement we get,

$$\begin{aligned} P \cos \theta &= W \sin \theta + F_A + F_B \\ &= W \sin \theta + f(R_A + R_B) \\ &= W \sin \theta + f(W \cos \theta + P \sin \theta) \end{aligned}$$

where W is the weight of the vehicle, P is the centrifugal force, f is the coefficient of friction, e is the transverse slope due to superelevation. Dividing by $W \cos \theta$, we get





Step 2

Find e for 75 percent of design speed, neglecting f , i.e. $e_1 = \frac{(0.75v)^2}{gR}$.

If $e_1 \leq 0.07$, then $e = e_1 = \frac{(0.75v)^2}{gR}$, else if $e_1 > 0.07$ go to step 3.

Step 3

Find f_1 for the design speed and max e , i.e. $f_1 = \frac{v^2}{gR} - e = \frac{v^2}{gR} - 0.07$. If $f_1 < 0.15$

, then the maximum $e = 0.07$ is safe for the design speed, else go to step 4.

Step 4

Find the allowable speed v_a for the maximum $e = 0.07$ and $f = 0.15$,

$$v_a = \sqrt{0.22gR} \quad v_a \geq v$$

If $v_a < v$ then the design is adequate, otherwise use speed adopt control measures or look for speed control measures

Maximum and minimum super-elevation

Depends on (a) slow moving vehicle and (b) heavy loaded trucks with high CG. IRC specifies a maximum super-elevation of 7 percent for plain and rolling terrain, while that of hilly terrain is 10 percent and urban road is 4 percent. The minimum super elevation is 2-4 percent for drainage purpose, especially for large radius of the horizontal curve.

Attainment of super-elevation

1. Elimination of the crown of the cambered section by:
 1. Rotating the outer edge about the crown : The outer half of the cross slope is rotated about the crown at a desired rate such that this surface falls on the same plane as the inner half.
 2. Shifting the position of the crown: This method is also known as diagonal crown method. Here the position of the crown is progressively shifted outwards, thus increasing the width of the inner half of cross section progressively.
2. Rotation of the pavement cross section to attain full super elevation by: There are two methods of attaining super elevation by rotating the pavement
 1. Rotation about the center line : The pavement is rotated such that the inner edge is depressed and the outer edge is raised both by half the total amount $E/2$ of super elevation, i.e., by $E/2$ with respect to the centre.
 2. Rotation about the inner edge: Here the pavement is rotated raising the outer edge as well as the centre such that the outer edge is raised by the full amount of super elevation with respect to the inner edge.

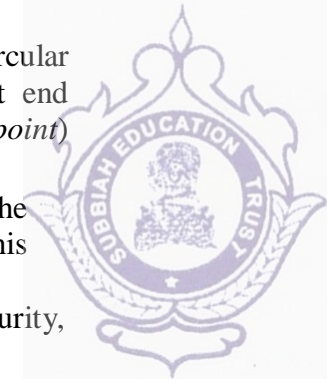

Transition curve is provided to change the horizontal alignment from straight to circular curve gradually and has a radius which decreases from infinity at the straight end (*tangent point*) to the desired radius of the circular curve at the other end (*curve point*)

There are five objectives for providing transition curve and are given below:

1. to introduce gradually the centrifugal force between the tangent point and the beginning of the circular curve, avoiding sudden jerk on the vehicle. This increases the comfort of passengers.
2. to enable the driver turn the steering gradually for his own comfort and security,
3. to provide gradual introduction of super elevation, and
4. to provide gradual introduction of extra widening.
5. to enhance the aesthetic appearance of the road.

Type of transition curve

Different types of transition curves are spiral or clothoid, cubic parabola, and Lemniscate. IRC recommends spiral as the transition curve because:

1. it fulfills the requirement of an ideal transition curve, that is;
 1. rate of change or centrifugal acceleration is consistent (smooth) and
 2. radius of the transition curve is ∞ at the straight edge and changes to R at

the curve point ($L_s \propto \frac{1}{R}$) and calculation and field implementation is very easy.

Length of transition curve

The length of the transition curve should be determined as the maximum of the following three criteria: rate of change of centrifugal acceleration, rate of change of super elevation, and an empirical formula given by IRC. Rate of change of centrifugal acceleration

At the tangent point, radius is infinity and hence centrifugal acceleration is zero. At the end of the transition, the radius R has minimum value R . The rate of change of centrifugal acceleration should be adopted such that the design should not cause discomfort to the drivers. If c is the rate of change of centrifugal acceleration, it can be written as:

$$\begin{aligned}
 c &= \frac{\frac{v^2}{R} - 0}{t}, \\
 &= \frac{\frac{v^2}{R}}{\frac{L_s}{v}}, \\
 &= \frac{v^3}{L_s R}.
 \end{aligned}$$

Therefore, the length of the transition curve L_{s1} in m is

$$L_{s_1} = \frac{v^3}{cR}, \quad (1)$$

where c is the rate of change of centrifugal acceleration given by an empirical formula suggested by IRC as below:

$$\text{subject to :} \quad c = \frac{80}{75 + 3.6v}, \quad (2)$$

$$c_{\min} = 0.5,$$

$$c_{\max} = 0.8.$$

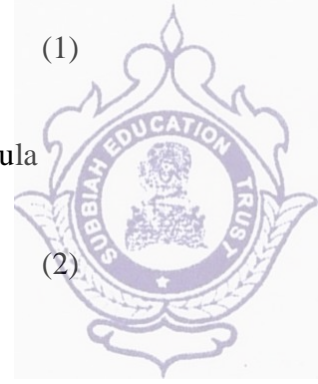

2. Rate of introduction of super-elevation

Raise (E) of the outer edge with respect to inner edge is given by

$$E = eB = e(W + W_e)$$

. The rate of change of this raise from 0 to E is achieved gradually with a gradient of 1 in N over the length of the transition curve (typical range of N is 60-150). Therefore, the length of the transition curve L_{s_2} is:

$$L_{s_2} = Ne(W + W_e) \quad (3)$$

3. By empirical formula

IRC suggest the length of the transition curve is minimum for a plain and rolling terrain:

$$L_{s_3} = \frac{35v^2}{R} \quad (4)$$

and for steep and hilly terrain is:

$$L_{s_3} = \frac{12.96v^2}{R} \quad (5)$$

$$s = \frac{L_s^2}{24R}$$

The length of the transition curve L_s is the maximum of equations 1, 3 and 4 or 5, i.e.

$$L_s = \text{Max} : (L_{s_1}, L_{s_2}, L_{s_3})$$

Case (a) $L_s < L_c$

For single lane roads:

$$\alpha = \frac{s}{R} \text{ radians}$$

$$= \frac{180s}{\pi R} \text{ degrees}$$

$$\alpha/2 = \frac{180s}{2\pi R} \text{ degrees}$$

Therefore,

$$m = R - R \cos\left(\frac{\alpha}{2}\right)$$

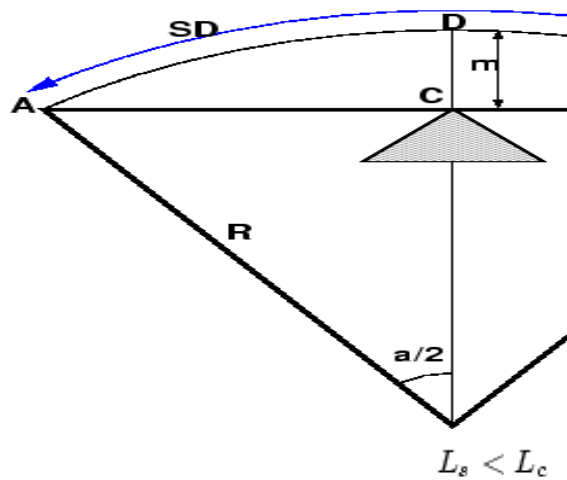

Figure 1: Set-back for single lane roads (



(
6
)

(
7
)

(
1
)

(
2
)

For multi lane roads, if d is the distance between centerline of the road and the centerline of the inner lane, then

$$m = R - (R - d) \cos \left(\frac{180s}{2\pi(R - d)} \right)$$

$$m = R - R \cos \left(\frac{\alpha}{2} \right)$$

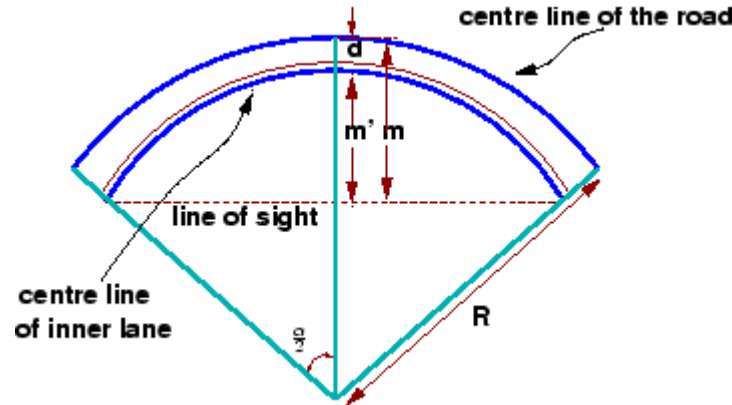
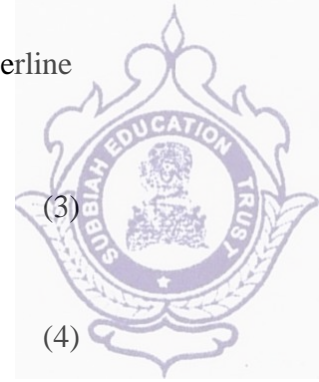

Figure 2: Set-back for multi-lane roads ($L_s < L_c$)

Case (a) $L_s < L_c$

For single lane roads:

$$\alpha = \frac{s}{R} \text{ radians}$$

$$= \frac{180s}{\pi R} \text{ degrees}$$

$$\alpha/2 = \frac{180s}{2\pi R} \text{ degrees} \tag{1}$$

Therefore,

$$m = R - R \cos \left(\frac{\alpha}{2} \right) \tag{2}$$

Gradient

Gradient is the rate of rise or fall along the length of the road with respect to the horizontal. While aligning a highway, the gradient is decided for designing the vertical curve. Before finalizing the gradients, the construction cost, vehicular operation cost and the practical problems in the site also has to be considered. Usually steep gradients are avoided as far as possible because of the difficulty to climb and increase in the

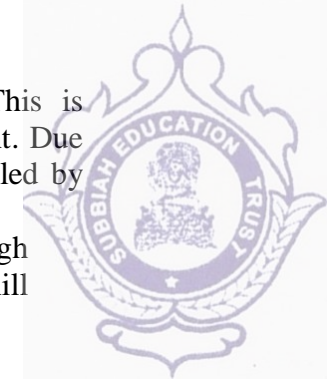

Effect of gradient

The effect of long steep gradient on the vehicular speed is considerable. This is particularly important in roads where the proportion of heavy vehicles is significant. Due to restrictive sight distance at uphill gradients the speed of traffic is often controlled by these heavy vehicles. As a result, not only the operating costs of the vehicles are increased, but also capacity of the roads will have to be reduced. Further, due to high differential speed between heavy and light vehicles, and between uphill and downhill gradients, accidents abound in gradients.

Representation of gradient

The positive gradient or the ascending gradient is denoted as $+n$ and the negative $-n$

gradient as $-n$. The deviation angle N is: when two grades meet, the angle which measures the change of direction and is given by the algebraic difference between the two

grades $(n_1 - (-n_2)) = n_1 + n_2 = \alpha_1 + \alpha_2$. Example: 1 in 30 = 3.33% is a steep gradient, while 1 in 50 = 2% is a flatter gradient. The gradient representation is illustrated in the figure [1](#).

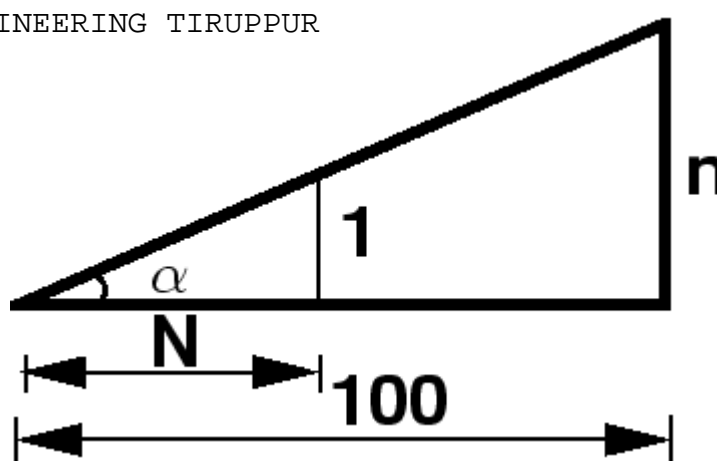

Figure 1: Representation of gradient

Types of gradient

Many studies have shown that gradient upto seven percent can have considerable effect on the speeds of the passenger cars. On the contrary, the speeds of the heavy vehicles are considerably reduced when long gradients as flat as two percent is adopted. Although, flatter gradients are desirable, it is evident that the cost of construction will also be very high. Therefore, IRC has specified the desirable gradients for each terrain. However, it may not be economically viable to adopt such gradients in certain locations, steeper gradients are permitted for short duration. Different types of grades are discussed below

Ruling gradient

The ruling gradient or the design gradient is the maximum gradient with which the designer attempts to design the vertical profile of the road. This depends on the terrain, length of the grade, speed, pulling power of the vehicle and the presence of the horizontal curve. In flatter terrain, it may be possible to provide flat gradients, but in hilly terrain it is not economical and sometimes not possible also. The ruling gradient is adopted by the designer by considering a particular speed as the design speed and for a design vehicle with standard dimensions. But our country has a heterogeneous traffic and hence it is not possible to lay down precise standards for the country as a whole. Hence IRC has recommended some values for ruling gradient for different types of terrain.

Limiting gradient

This gradient is adopted when the ruling gradient results in enormous increase in cost of construction. On rolling terrain and hilly terrain it may be frequently necessary to adopt limiting gradient. But the length of the limiting gradient stretches should be limited and must be sandwiched by either straight roads or easier grades.

Exceptional gradient

Exceptional gradient are very steeper gradients given at unavoidable situations. They should be limited for short stretches not exceeding about 100 metres at a stretch. In mountainous and steep terrain, successive exceptional gradients must be separated by a minimum 100 metre length gentler gradient. At hairpin bends, the gradient is restricted to 2.5%.

Critical length of the grade

The maximum length of the ascending gradient which a loaded truck can operate without undue reduction in speed is called critical length of the grade. A speed of 25 kmph is a

initial speed, final desirable minimum speed

Minimum gradient

This is important only at locations where surface drainage is important. Camber will take care of the lateral drainage. But the longitudinal drainage along the side drains require some slope for smooth flow of water. Therefore minimum gradient is provided for drainage purpose and it depends on the rain fall, type of soil and other site conditions. A minimum of 1 in 500 may be sufficient for concrete drain and 1 in 200 for open soil drains are found to give satisfactory performance.



Sight distance available from a point is the actual distance along the road surface, which a driver from a specified height above the carriage way has visibility of stationary or moving objects.

Sight distance required by drivers applies to both geometric design of highways and for traffic control. The sight distance situations are considered in the design.

- i) Stopping or absolute minimum sight distance
- ii) Safe overtaking or passing sight distance
- iii) Safe sight distance for entering into uncontrolled intersections.

Apart from the three situations mentioned above the following sight distance are considered by the IRC in highway design:

Intermediate sight distance:

This is defined as twice the stopping sight distance when overtaking sight distance cannot be provided; intermediate sight distance is provided to give limited overtaking opportunities to fast vehicles.

Head light sight distance:

This is the distance visible to a driver during night driving under the illumination of the vehicle head lights.

Stopping sight distance:

The minimum sight distance available on a highway at any spot should be of sufficient length to stop a vehicle traveling at design speed, safely without collision with any other obstruction.

The absolute minimum sight distance is therefore equal to the stopping sight distance which is also sometimes called nonpassing sight distance. The sight distance available on a road to a driver at any instance depends on,

- i) Features of the road
- ii) Height of the drivers eye above the road surface
- iii) Height of the object above the road surface.

The distance within which a motor vehicle can be stopped depends upon the factors listed below,

- a) Total reactions time of the driver
- b) Speed of vehicle
- c) Efficiency of breaks
- d) Frictional resistance between the road and tyres.
- e) Gradient of the road.

Total reaction time:

*) Reaction time of the driver is the time taken from the instant the object is visible to the driver to the instant the brakes are effectively applied.

*) The total reaction time may be split up into two parts.



PIEV theory:

According to this theory the total reaction time of the driver is split into four parts:

- i) Perception
- ii) Intellection
- iii) Emotion
- iv) Volition

Speed of Vehicle:

The stopping distance depends very much on the speed of the vehicle; first during the total reaction time of the driver the distance moved by the vehicle will depend on the speed.

Efficiency of brakes:

The braking efficiency is said to be 100 percent if the wheels are fully locked preventing them from rotating on application of the brakes. This will result in 100 percent skidding which is normally undesirable except in utmost emergency.

Frictional resistance between road and tyres:

The frictional resistance developed between road and tyres or the skid resistance depends on the type and condition of the road surface and the tyres. IRC has specified a design friction coefficient of 0.35 to 0.4 depending upon the speed to be used for finding the braking distance in the calculation of stopping sight distance.

Analysis of stopping distance:

- i) The distance traveled by the vehicle during the total reaction time known as lag distance.
- ii) The distance traveled by the vehicle after the application of the brakes is known as braking distance.

Overtaking sight distance:

The minimum distance open to the vision of the driver of a vehicle intending to overtake slow vehicle ahead with safety against the traffic of opposite direction is known as the minimum overtaking sight distance(OSD) or Safe passing sight distance available.

The overtaking sight distance is the distance measured along the center of the road which a driver with his eye level 1.2m above the road surface can see the top of an object 1.2m above the road surface

Some of the important factors on which the minimum overtaking sight distance required.

- a) Speed of
 - i) overtaking vehicle
 - ii) overtaken vehicle
 - iii) The vehicle coming from opposite direction
- b) Distance between the overtaking and overtaken vehicles; the minimum spacing depends on the speeds.
 - a) Skill and reaction time of the driver.
 - b) Rate of acceleration of overtaking vehicle
 - c) Gradient of the road.

Criteria for sight distance requirements on highway:

*) The absolute minimum sight distance required throughout the length of the road is the SSD which should invariably be provided at all places.

JAIRUBAA COLLEGE OF ENGINEERING
* On vertical summit curves the obstruction on the inner side of the curves should be cleared to provide the required set back distance and absolute minimum sight distance.

*) On vertical summit curves the sight distance requirement may be fulfilled by proper design of the vertical alignment.

Hairpin bent

TYPES OF CURVES ON HILL ROADS

The following are the important types of curves provided on hill Roads:-

1. **Hair-Pin Curves**
2. **Salient Curves**
3. **Re-entrant Curves**

1. Hair-pin curves: - The curve in a hill road which changes its direction through an angle of 180 degree or so, down the hill on the same side is known as hair-pin curve.



A Hair-Pin Bend

This curve is so called because it conforms to the shape of a **hair-pin**. The bend so formed at the **hair-pin** curve in a hill road is known as **hair-pin bend**. This type of curve should be located on a hill side having the minimum slope and maximum stability. It must also be safe from view point of landslides and ground water. **Hair-pin bends** with long arms and farther spacing are always preferred. They reduce construction problems and expensive protective works. **Hair-pin** curves or bends of serpentine nature are difficult to negotiate and should, therefore, be avoided as far as possible.

Salient curves: - The curves having their convexity on the outer edges of a hill road are called salient curves. The centre of curvature of a salient curve lies towards the hill side. This type of curve occurs in the road length constructed on the ridge of a hill. the bend so formed at the salient curve in a hill road known as corner bend.

Salient curves are very dangerous for fast moving traffic. At such a curve or at corner bend, the portion of projecting hill side is usually cut down to improve the visibility as shown in fig. (Re-entrant curve). The outer edge of the road at such a curve is essentially provided with a parapet wall for protection of the vehicles from falling down the hill slope.



Re-entrant curves

The centre of curvature of a re-entrant curves lies away from the hill side. This type of curve occurs in the road length constructed in the calley of a hill.

These curves are less dangerous as they provide adequate visibility to the fast moving traffic. At such curves, the parapet wall is provided only for safety of fast moving traffic.

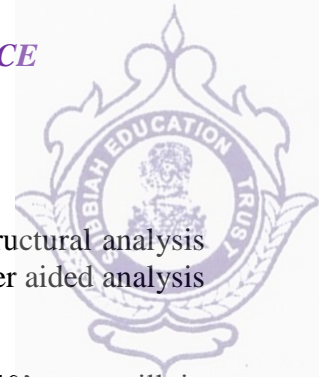

COMPARISON OF RIGID AND FLEXIBLE PAVEMENTS

The comparisons are:

i) Design precision

A cement concrete pavement is amenable to a much more precise structural analysis than a flexible pavement. Flexible pavements designs are mainly empirical. Computer aided analysis of layered system is making the flexible pavement design more exact than hitherto.

ii) Life

*) Cement concrete slabs of a thin section constructed in the early 1940's are still in existence in India though many of them have cracked badly and a few of them have been ripped open and rebuilt in recent times.

*) A major project in cement concrete road construction between Agra and Mathura. It can safely be said that a well-designed concrete slab has a life of about 40 years.

*) Compared to this the life of a flexible pavement generally varies from 10 to 20 years..

iii) Maintenance:

*) A well-designed cement concrete pavement needs very little maintenance. The only maintenance needed is in respect of joints.

*) The surface is unaffected by spillage of oil and lubricants, bituminous surfaces on the other hand, need great inputs in maintenance.

*) The surface is affected by spillage of oil and lubricants. The surface is also affected by natural weathering agents like air, water and temperature changes.

*) A cement concrete pavement on the other hand needs a small amount for maintaining joints.

iv) Initial cost:

*) The argument so far used against a cement concrete slab is that it is much more costly than a flexible pavement.

*) The latter specifications no doubt represent the rock-bottom needs of a road in India, but these specifications can hardly provide a smooth and durable surface.

v) Stage construction:

*) Road construction is generally done adopting a policy of stage construction especially for low volume roads. As traffic grows, additional layers in the form of water bound macadam and superior surfacing are added on.

*) Initial outlay is minimum and additional outlays are in keeping with traffic growth. This is a great advantage when dealing with new roads in an atmosphere of austerity.

vi) Availability of materials:

*) Cement, bitumen, stone aggregates and gravel/sand are the major materials involved in pavement construction. Cement has been in serious short supply in the country for the past many decades.

*) Bitumen is also not available plentifully in India. There is also the danger of the entire oil reserves in the world shrinking during the next two or three decades.

*) In locations where stone aggregates are scarce, cement concrete may have an advantage for flexible pavements

vii) Surface characteristics:

JAIIRUBAA COLLEGE OF ENGINEERING AND TECHNOLOGY
A well-constructed concrete surface is smooth and free from rutting, potholes and corrugations. In a bituminous surface it is only the asphaltic concrete surface that can give comparable rideability.

*) A well-constructed cement concrete pavement surface can have a permanent nonskid surface. A bituminous surface can also be designed to have a good skid resistant surface.

viii) Utility location:

*) In cement concrete slabs, proper thought has to be given to locate utilities ,such as water pipes, telephone lines and electric cables.

*) It is difficult to rip open the slab and restore it to be the original condition ,if any changes in the utilities lines are to be made.

ix) Glare and night visibility:

*) Concrete pavements have a gray color which can cause glare under sunlight. Colored cement can reduce the glare.

*) On the other hand, bituminous roads need more street lighting.

x) Traffic dislocation during construction:

*) A cement concrete pavement requires 28 days before it can be thrown open to traffic. On the other hand, a bituminous surface can be thrown open to traffic shortly after it is rolled.

xi) Environmental considerations during construction:

*) The process of heating of bitumen and aggregates and mixing them together on hot mix plants, can prove to be much more hazardous to the environment than cement concrete construction where no heating of any material is involved.

xii) Overall economy on a life cycle basis:

*) A good road is costly to construct but once constructed such a road requires little maintenance and results in savings in vehicle operating costs.

*) The comparative economy of a flexible pavement and a rigid pavement has proved that on overall economic considerations.

Types of pavement structure

Based on the structural behavior, pavements are generally classified into three categories:

- i) Flexible pavements
- ii) Rigid pavements
- iii) Semi rigid pavements

Flexible pavements:

*) Flexible pavements are those, which on the whole have low or negligible flexural strength and are rather flexible in their structural action under the loads. The flexible pavement layers reflect the deformation of the lower layers on to the surface of the layer.

*) A flexible pavement consists of four components (i) Soil subgrade (ii) sub base course (iii) base course (iv) Surface course.

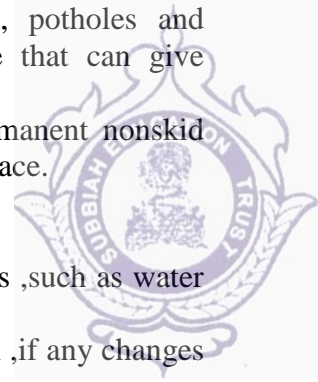

*) The flexible pavements do not permit the vertical or compressive stresses to the lower layers by grain to grain transfer through the points of contact in the granular structure. A well compacted granular structure consisting of strong added aggregate can transfer the compressive stresses.

*) The load spreading ability of this layer therefore depends on the type of the materials and mix design factors. Bituminous concrete is one of the best flexible pavements layer materials. Other materials which fall under the group are all granular materials with or without bituminous binder, granular base and sub base course materials.

*) The vertical compressive stress is maximum on the pavement surface directly under the wheel and is equal to the contact pressure under the wheel. The flexible pavement may be constructed in a number of layers and the top layer has to be strongest as the highest compressive stresses.

*) Flexible pavements are commonly designed using empirical design charts or equations taking into account some of the design factors, there are also semi empirical and theoretical design methods.

Rigid pavements:

*) Rigid pavements are those which possess not flexural strength or flexural rigidity. The stresses are not transferred from grain to grain to the lower layers as in the case of flexible pavements layers.

*) The rigid pavements are made of Portland cement concrete plain, reinforced or prestressed concrete. The plain cement concrete slabs are expected to take up about 40 kg/cm^2 flexural stress.

*) The rigid pavement has the slab action and is capable of transmitting the wheel load stresses through a wider area below. The main point of difference in the structural behavior of rigid pavement as compared to the flexible pavement is that the critical condition of stress in the rigid pavement is the maximum flexural stress occurring in the slab due to wheel load and the temperature changes whereas in the flexible pavement .

*) As the rigid pavement slab has tensile strength, tensile stresses are developed due to the bending of the slab under wheel load and temperature variations. Thus the types of stresses developed and their distribution within the cement concrete slab are quite different.

*) The cement concrete pavement slab can very well serve as a wearing surface as well as an effective base course. The rigid pavement structure consists of a cement concrete slab, below which a granular base or sub base course may be provided.

*) Though the cement concrete slab can also be laid directly over the soil subgrade, consists of fine grained soil.

*) the rigid pavements are usually designed and the stresses are analyzed using the elastic theory, assuming the pavements as an elastic plate resting over an elastic or a viscous foundation.

Semi rigid pavements:

*) when bonded materials like the pozzolanic concrete, lean cement concrete or soil cement are used in the base course or sub base course layer the pavement layer has considerably higher flexural strength than the common flexible pavement layers.

*) when this intermediate class of materials are used in the base or sub base course layer of the pavements, they are called semi rigid pavements.

semi rigid pavement are either designed as flexible pavements with some correction factors to find the thickness requirements based on experience or by using a new design approach.

*) The semi rigid pavement materials have low resistance to impact and abrasion and therefore are usually provided with flexible pavement surface course.



Various functions of pavement components

The functions are:

Soil sub grade and its evaluation:

*) The soil sub grade is a layer of natural soil prepared to receive the layers of pavement materials placed over it. It is essential that at no time the soil sub grade is overstressed, it means that the pressure transmitted on the top of the sub grade is within the allowable limit.

*) Many tests are known for measuring the strength properties of the sub grades. Some of the tests have been standardized for the use. The common strength test for the evaluation of soil subgrade is:

- i) California bearing ratio test.
- ii) California resistance value test.
- iii) Triaxial compression test
- iv) Plate bearing test.

CALIFORNIA BEARING RATIO (CBR) TEST:

It is evolved for the empirical method of flexible pavement design. The CBR test is carried out either in the laboratory on prepared specimens or in the field by taking in situ measurements.

California resistance value:

It is found by using have been stabliometer.This test is used in an empirical method of flexible pavement design based on soil strength.

Triaxial test:

It is the most important soil strength, but still the test is not very commonly used in structural design of pavements.

Plate bearing test:

It is carried out using a relatively large diameter plate to evaluate the load supporting capacity of supporting power of the pavement layers. The results are plate bearing tests are used in flexible pavement design method like McLeod method on based on layer system analysis by brumister.

Sub base and base courses and their evaluation:

*) There layers are made of broken stones, bound or unbound aggregate,some times in sub base course a layer of stabilized soil.(or) Selected granular soil is also used.

*) however at the sub base course it is desirable to use smaller size graded aggregates. When the sub grade consists of fine grained soil and when the pavement carries heavy wheel loads.

JAI RUBAA COLLEGE OF ENGINEERING AND TECHNOLOGY
Sub base course performs primarily the similar function as of the base course and is provided with inferior materials than of base course. Base courses are used, under rigid pavement for

- i) Preventing pumping
 - ii) Protecting the sub grade against frost action.
- *) Thus the fundamental purpose of a base course and sub base course is to provide a stress transmitting medium to spread the surface wheel loads in such manner.
- *) The sub base and base course layers may be evaluated by suitable strength or stability test like plate bearing CBR test.

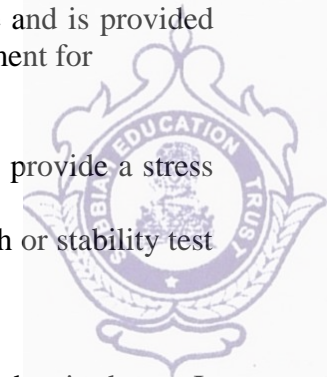

WEARING COURSE AND ITS EVALUATION:

- *) The purpose of the wearing course is to give a smooth riding surface that is dense. It resists pressure exerted by tyres and takes up wear and tear due to the traffic.
- *) Wearing course also offers a water tight layer against the surface water infiltration. The flexible pavement normally a bituminous surfacing is used as a wearing course.
- *) In rigid pavements, the cement concrete acts like a base course as well as wearing course. Most popular test in use is Marshall stability test where in the optimum content of bitumen binder is worked out based on the stability density.
- *) Plate bearing test and Bankelman beam test are also sometimes made use of for evaluating the wearing course and the pavement as a whole.

Various factors to be considered in pavement design and the significance

Pavement design consists of two parts:

- i) Mix design of materials to be used in each pavement component layer. Thickness design of the pavement and the component layers.

The various factors to be considered for the design of pavements are given below:

- i) Design wheel load
- ii) Sub grade soil
- iii) Climatic factors
- iv) Pavement component layers.
- v) Environmental factors
- vi) Special factors in the design of different types of pavements.

Design wheel load:

The various wheel load factors to be considered in pavement design are:

- i) Maximum wheel load
- ii) Contact pressure
- iii) Dual or multiple wheel loads
- iv) Repetition of loads.

Maximum wheel load:

The wheel load configurations are important to know the way in which the loads of a given vehicle are applied on the pavement surface.

*) For highways the maximum legal axle load as specified by Indian road congress is 8170 kg with a maximum equivalent single wheel load of 4085 kg.

*) The evaluation for vertical stress computations under a uniformly distribute of circular load based on Boussineq's theory is given by:



$$\sigma_z = p \left[1 - \frac{z^3}{(a^2 + z^2)^{\frac{3}{2}}} \right]$$

σ_z = vertical stress at depth z
 P= surface pressure
 Z=depth at which σ_z computed.
 A=radius of loaded area.

Contact pressure:

Generally the wheel load is assumed to be distributed over a circular area. But by measurement of the imprints of tyers with different load and inflation pressures. Three terms in use with reference to tyre pressure are:

- Tyre pressure
- Inflation pressure
- Contact pressure

Tyre pressure and inflation pressure mean exactly the same .the contact pressure is found to be more than tyre pressure when the tyre pressure is less than 7 kg/m² and it is vice versa when the tyre pressure exceeds this value.

Contact pressure can be measured by the relationship

$$\text{Contact pressure} = \frac{\text{Load on wheel}}{\text{Contact area or area of imprint}}$$

The general variation between the tyre pressure and measured contact pressure is shown in this fig. The ratio of contact pressure to type pressure is defined as rigidity factor. Thus value of rigidity factor is 1.0 for an average tyre pressure of 7 Kg/cm².This value is higher than unity for lower type pressures and less than unity for tyre pressures higher than 7 kg/cm².

Equivalent single wheel load (ESWL):

*) The maximum wheel load within the specified limit and to carry greater load it is necessary to provide dual wheel assembly to the rear axles of the roads vehicles.

*) In other words the pressure at a certain depth below the pavement surface cannot be obtained by numerically adding the pressure caused by any one wheel.

*) The effect is in between the single load and two times load carried by one wheel. The load dispersion is assumed to be at an angle of 45⁰.In the dual wheel load assembly let d be the clear gap between the two wheels ,S be the spacing between the centers of the wheels and a be the radius of the circular contact area of each wheel. Then S = (d + 2a).

*) ESWL may be determined based on either equivalent deflection or equivalent stress criterian.Multiple wheel loads are convert to ESWL and this value is used in pavement design. The ESWL is usually determined by the equivalent stress criterion using a simple graphical method.

JAIRUBAA COLLEGE OF ENGINEERING & TECHNOLOGY
* A single wheel load is assumed between ESWL and depth on log scales. For determining ESWL the plot is made as shown in fig.

*) Two points A and B are plotted on the log-log graph with coordinates of A (P,d/2) and B(2p,2s), line AB is a plot which is the focus of points where any single wheel load is equivalent to a certain set of dual wheels.

*) To Calculate the ESWL for a dual assembly it is essential to estimate a design thickness of the pavement. If the design thickness so obtained is equal to the estimated thickness then the ESWL calculations could be considered as correct. Otherwise trials are made.

*) In heavy trucks and trailers the load on each wheel may be further reduced by multiple wheels and tandem axles.

Repetition of loads:

*) The deformation of load pavement (or) sub grade due to a single application of wheel load may be small. It required carrying out traffic surveys for accounting the factor of repetitions for wheel loads in the design of pavement.

*) Data collected are converted to some constant equivalent wheel loads. Equivalent wheel load is a single load equivalent to the repeated applications of any particular wheel load on a pavement which requires the same thickness and strength of pavements.

*) McLeod has given a procedure for evolving equivalent load factors for designing flexible pavements.

Various methods of flexible pavement design

*) The flexible pavement is built with number of layers. In the design process it is to be ensured that under the application of load none of the layers is overstressed.

*) The maximum intensity of stresses occurs in the top layer of the pavement .The magnitude of load stresses reduces at lower layers.

*) In the design of flexible pavements, it has yet not been possible to have a rational design method wherein design process and service behavior of the pavement can be expressed by mathematical laws.

*) Flexible pavement design methods are accordingly either empirical or semi empirical. In these methods, the knowledge and experience gained on the behavior of the pavements in the past are usefully utilized.

Various approaches of flexible pavement design may be thus classified into three groups:

- i) Empirical method
- ii) Semi-empirical or Semi theoretical method
- iii) Theoretical method

*) Empirical methods are either based on physical properties or strength parameters of soil sub grade. When the design is based on stress strain function and modified base on experience it may be called semi-empirical or semi-theoretical. There are design methods based on theoretical analysis and mathematical computations.

Out of the flexible pavement design method available is

- i) Group index method
- ii) California bearing ratio method
- iii) California R value (or) Stabilometer method
- iv) Triaxial test method

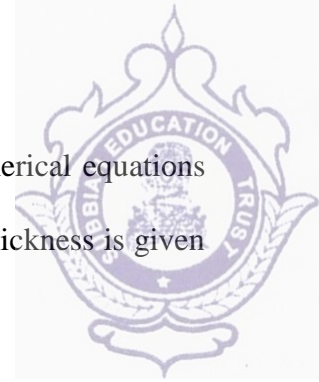

Group index method:

*) Group index value is an arbitrary index assigned to the soil type in numerical equations base on the percent fines liquid limit and plasticity index.

*) The design chart for group index method for determining the pavement thickness is given in fig.

The traffic volume in this method is divided in three groups.

Traffic volume	No of vehicles per day
Light	Less than 50
Medium	50 to 300
Heavy	Over 300

The design of the pavement thickness by this method, first the G1 value of the soil is found the anticipated traffic is estimated and is designated as light, medium or heavy as indicated

The G1 method of pavement design is essentially an empirical method based on physical properties of the subgrade soil. This method does not consider the strength characteristics of the subgrade soil and therefore is open to question regarding the reliability of the design based on the index properties of the soil only.

California bearing ratio method:

*) California division of highways in the U.S.A. developed CBR method for pavement design. The majority of design curves developed later are base on the original curves proposed by O.J.porter.

*) One of the chief advantages of CBR method is the simplicity of the test procedure. The CBR tests were carried out by the California state highway department on existing pavement layers including subgrade, sub base and base course.

*) Based on the extensive CBR test data collected on pavement which behaved satisfactory and those which failed, an empirical design chart was developed correlating the CBR value and the pavement thickness. The basis of the design chart is that a material with a given CBR required a certain thickness of pavement layer as a cover.

*) A higher load needs a thicker pavement layer to protect the sub grade. Design curves correlating the CBR value with total pavement thickness cover were developed by the California state highway department for wheel loads of 3175kg and 5443 kg representing light and heavy traffic. The design curves are shown in this fig.

It is possible to extend the CBR design curves for various loading conditions, nusing the expression:

$$t = \sqrt{p \left[\frac{1.75}{CBR} - \frac{1}{p\pi} \right]^{\frac{1}{2}}}$$

$$t = \left[\frac{1.75p}{CBR} - \frac{A}{\pi} \right]^{\frac{1}{2}}$$

Hence,

t= pavement thickness, cm

p=Wheel load, kg

CBR= California bearing ratio, percent

P=tyre pressure, kg/cm²

A= area of contact.cm²

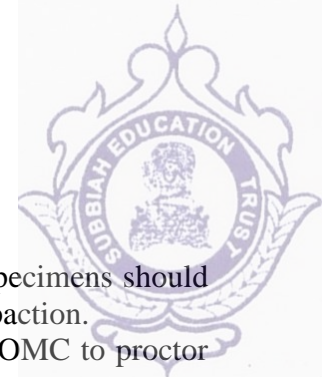

IRC Recommendations:

- a) The CBR tests should be performed on remoulded soils in the laboratory. The specimens should be prepared by static compaction wherever possible and otherwise by dynamic compaction.
- b) For the design of new roads, the sub grade soil sample should be compacted at OMC to proctor density whenever suitable compaction equipment.
- c) The CBR test samples may be soaked in water for four days period before testing .the annual rainfall is less than 50 cm and the water table is too deep to affect the sub grade and imperable surfacing is provided to carrying out CBR test.
- d) If the maximum variations in CBR value of the three specimens exceed the specified limits, the design CBR should be average of at least six samples.
- e) The top 50 cm of sub grade should be compacted at least up to 95 to 100 percent of proctor density.
- f) An estimate of the traffic should be carried by the road pavements at the end of expected in view the existing traffic and probable growth rate of traffic.
- g) The traffic for the design is considered in units of heavy vehicles per day in both directions and is divided into seven categories A to G. The design thickness is considered applicable for single axle loads up to 8200 kg and tandom axle loads up to 14,500 kg.
- h) When sub base course materials contain substantial proportion of aggregates of size above 20mm, the CBR value of these materials would not be valid for the design of subsequent layers above them. The CBR method of pavement design gives the total thickness requirement of the pavement above a sub grade and thickness value would remain the same quality of materials used in component layers.

California resistance value method:

*) In this design method based on stabliometer R-value and cohesiometer C-value .Based on performance data it was established by pavement thickness varies directly with R value and algorithm of load repetitions. It varies inversely with fifth root of c value.The expression for pavement thickness is given by the empirical equation:

$$T = \frac{K(T_1)(90 - R)}{C^{\frac{1}{5}}}$$

Hence,

T=total thickness of pavement, cm

K=Numerical constant 0.166

T₁=traffic index

R= stabliometer resistance value

C=Cohesiometer value

data are needed:

*) R-value of soil subgrade

*) T₁ value

*) Equivalent C-value

*) R value of soil subgrade is obtained from the test using stablio meter.The computation of T₁ value has been explained.



Equivalent C-value:

*) The cohesion meter value c is obtained for each layer of pavement material separately from tests. However the composite or equivalent C-value of the pavement may be estimated if the thickness of each component layer and the c-value of the material of the layer are known.

*) while designing a pavement as the thickness of the pavement is not known, it is easier if the pavement is first assumed to consist of any one material like gravel base course with known C-value.

*) Subsequently the individual thickness of each layer is converted in terms of gravel equivalent by using relationship:

$$\frac{t1}{t2} = \left(\frac{C_2}{C_1} \right)^{\frac{1}{5}}$$

*) t1 and t2 are the thickness values of any two pavement layers.c1 and c2 are their corresponding cohesiometer values.



UNIT IV RAILWAY PLANNING AND CONSTRUCTION

(PART-A)

1. List the various gauges used in Indian Railways? (May/ June 2012)

- a) Broad Gauge (B.G.) – 1.67 mtrs.
- b) Meter Gauge (M.G.) – 1.00 mtrs.
- c) Narrow Gauge (N.G.) – 0.762 mtrs.
- d) Light Gauge or Freeder Track Gauge – 0.610 mtrs.

2. Give the various functions of rails? (May/ June 2011)

1. Rails provide a hard, smooth and unchanging surface for passage of heavy moving loads with a minimum friction between the steel rails and steel wheels.
2. Rails bear the stresses developed due to heavy vertical loads, lateral and barking forces and thermal stresses.
3. The rail material is such that it gives minimum wear to avoid replacement charges and failures of rails due to wear.

3. Define obligatory point. (May/ June 2012)

Obligatory points are controlling points which govern the alignment of railway tracks. Some important obligatory points are; (i) Important towns and cities (ii) Shortest width and permanent path of rivers (iii) Hill passess.

4. What are the disadvantages of “Coning of wheels”? (Nov/ Dec 2012)

The disadvantages are;

- ✓ Pressure of horizontal components near the inner edge of rails has a tendency to accelerate wearing of rails.
- ✓ It tends to turn rails outwardly and consequently, the gauge is widened.
- ✓ Cause damages to outer edge of rails, if no base plates are provided.

5. What is meant by cant deficiency? (Nov /Dec 2012)

The equilibrium cant is provided on the basis of the average speed of different trains on the track. This equilibrium cant or super elevation will fall short of that required for speed higher than average speed. This storage of cant is called cant deficiency.



6. What are the various types of the Gradients that are adopted in laying a railway track? (May /June 2013)

- (1) Ruling gradients
- (2) Momentum gradients
- (3) Pusher gradients
- (4) Gradients in station yards.

7. On a B.G track of 4° curve, equilibrium cant is provided for a speed of 60 km/hr. Calculate

- (i) Value of equilibrium cant
- (ii) Maximum speed allowing maximum deficiency (May /June 2013)

Given data:

Degree of curve = 4°

Nominal Gauge (B.G) = 1750 mm

Speed of train = 60 km/hr

Solution

Radius of curvature $R = 1750/D = 1750/4 = 437.5 \text{ m}$

$$\text{Equilibrium cant } e = \frac{GV^2}{127R} = 1750 \times 60^2 / 127 \times 437.5 = 113.39 \text{ mm}$$

8. List the uses of Remote sensing in route alignments. (Nov / Dec 2013)

Gives a birds' eye view of a large areas. Ground condition can be defined with a combination of satellite images and topographic maps.

9. Mention the functions of formation (Nov / Dec 2013)

Formation is the base over which the ballast is spread. Sometimes the natural ground may not meet the requirements for placing ballast. In such cases a raised bank is constructed over the natural ground which is called the embankment. Sometimes, the formation below the natural ground is made which is called cutting.

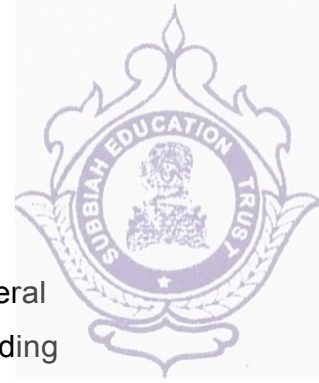

10. What is creep? How is it prevented? (Nov/ Dec 2014)

Creep is the longitudinal movement of rails in a track. It occurs due to several reasons. The effect of creep tends to dig the track. It is prevented by providing sufficient ballast which could hold the rails.

11. What do you mean by sleeper density? (Nov/ Dec 2014)

Sleeper density is defined as the number per rail length. It is specified as

$M + x$ where M is the length of the rail in metres
 x is the number that varies

12. Sketch the cross section of a permanent way (May/ June 2015)

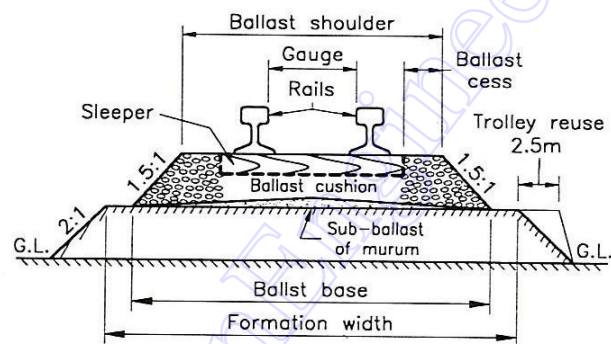

Typical Cross-section of a Permanent Way on Embankment.



PART B

1. Explain the permanent way components with neat sketch. (May / June 2013)

The combination of rails, fitted on sleepers & resting on ballast & subgrade is called as railway track or permanent track something temporary tracks.

In permanent way, the rails are joined in series by fish plate & bolts and then they are fixed to sleeper by different types of fastening.

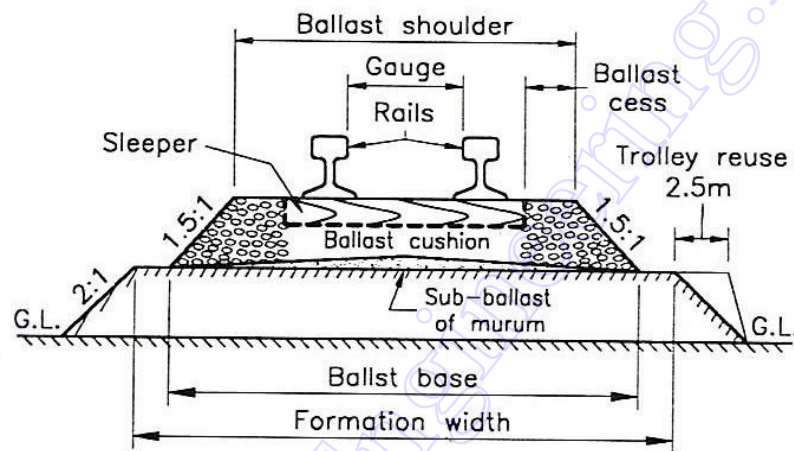

Typical Cross-section of a Permanent Way on Embankment.

Permanent way

Rails:

Rails are unsymmetrical I sections, made up of steel. They are laid along two parallel lines over sleepers. Rails are joined longitudinally by fish plate or by welding. These are placed end to end to provide a continuous & level surface for trains to move.

Types of rails.

1. Double headed rails.
2. Bull headed rails
3. Flat footed rails.

Functions:

1. Act as guide and transmit load to large area of formation through sleepers and ballast..

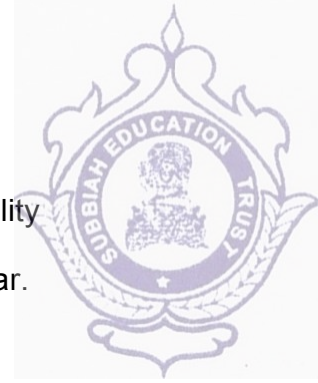

2. It should be an economic section consistent with strength stiffness and durability
3. The head of rail should have adequate depth to allow for allow for vertical wear.
4. Web should be sufficiently thick to withstand stresses.

Sleepers.

Sleepers are members generally laid transverse to the rails on which the rails are supported and fixed, to transfer the loads from rails to the ballast and subgrade below.

Functions of sleepers:

Sleepers perform the following functions,

1. To hold the rails to correct gauge.
2. To hold the rails in proper level or transverse tilt i.e., level in turnouts, cross-overs,
3. To act an elastic medium between the ballast and rails to absorb the blows and vibrations of moving loads.
4. To distribute the loads from the rails to index area of ballast underlying it or to the girders in case of bridges.
5. They also provide means to rectify track geometry during service life.

Ballast: layer of material which is place below and packed around sleepers for distribution of load from sleepers to the formation.

Functions:

- (i) Provides level and hard bed for sleepers
- (ii) To hold sleepers while passage of trains
- (iii) Forms a load distribution medium between sleepers and formation
- (iv) Provides elasticity and resilience to the track for proper riding comfort.
- (v) Acts a draining of water.
- (vi) Resists lateral, longitudinal and vertical displacements of the track

Types:

- | | | |
|------------------|-------------|---------------------------|
| (i) Broken stone | (ii) Gravel | (iii) coal or ash cinders |
| (ii) Sand | (v) Moorum | (vi) Selected earths |



2. If a 8° curve track diverges from main curve of 5° in an opposite direction in the layout of a B G yard. Calculate the super elevation and speed on branch line, if the maximum speed permitted on the main line is 45 kmph. (Nov / Dec 2010) (8 mark)

Solution:

Radius of main curve,

$$R_m = \frac{1719}{8} = 214.9 \text{ m}$$

Radius of branch curve,

$$R_b = \frac{1719}{5} = 348.8 \text{ m}$$

Super elevation of main line,

$$e_m = 1.315 \frac{V^2}{R}$$

$$e_m = \frac{1.315 \times 45^2}{214.9}$$

$$= 12.39 \text{ cm}$$

Assume cant deficiency as 76 mm = 7.6 cm

Theoretical super elevation on main line = Cant deficiency + change in super elevation (e_{ch})

$$12.39 = 7.6 + e_{ch}$$

$$e_{ch} = 12.39 - 7.60 = 4.79 \text{ cm}$$

$$e_{ch} = e_b - 7.6$$

$$-4.79 = e_b - 7.6$$

i.e.,

$$e_b = 2.81 \text{ cm}$$

Super elevation of branch = 2.81 cm

Speed of branch line = $\sqrt{e_b \times R}$

$$1.315$$

$$= 27.10 \text{ kmph}$$

Speed of branch line = 27.10 kmph

3. What are the requirements of an ideal rail joint? Explain the various rail joints used in railways with neat sketches. (Nov / Dec 2013)

Requirements of Ideal Rail Joints:

Two rails are connected by a joint which forms the weakest part of the track.



Different fastenings are used to make this joint as much efficient as possible. The characteristics of a good ideal rail joint are as follows:

- The rail joint should hold the two ends of rails as nearly as possible and should be at same level in a straight line.
- It should have the same strength and stiffness with rails.
- It should provide space for expansion and contraction of rails due to changes in temperature.
- It should be arranged in such a way that any rail while repair.
- It should be durable, cheap in initial cost and maintenance.
- It should provide sufficient elasticity to absorb vibrations and shocks.
- It should provide resistance to the longitudinal forces developed due to acceleration, deceleration.
- The joint fittings should be simple and universal type so that it can be used for all types of sleepers.

Types of Rail joints:

Depending upon the position of joints or sleepers, rails are classified as

(1) According to position of joints:

- Square joints
- Staggered joints

Square joint: When a joint in one rail is exactly opposite to the joint in the parallel rail, it is known as a square joint and it is very common in straight track.

Staggered joint: When a joint in one rail is exactly opposite to the centre of the parallel rail length, it is known as a staggered joint.

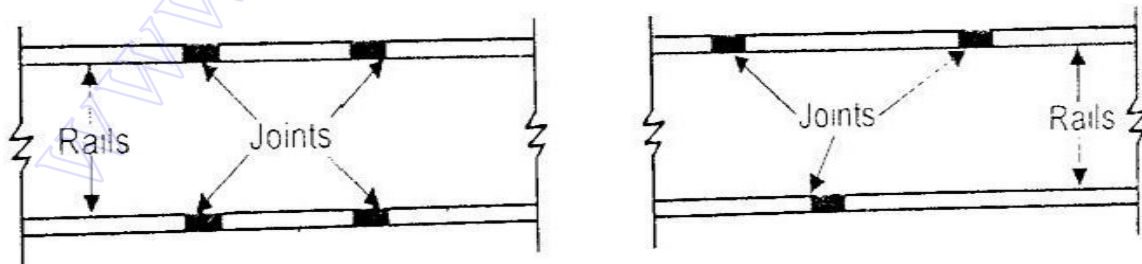

(a) Square joints

(b) Staggered joints

PLAN



(2) According to position of sleepers:

- Suspended joints
- Supported joints
- Bridge joints

Suspended joint:

The rail joint, when placed at the centre of two consecutive sleepers is known as suspended joint.

In this type of joint, load will be equally distributed on sleepers and also when joint is depressed, rail ends are pressed down evenly.

It is most commonly adopted since it provides greater elasticity.

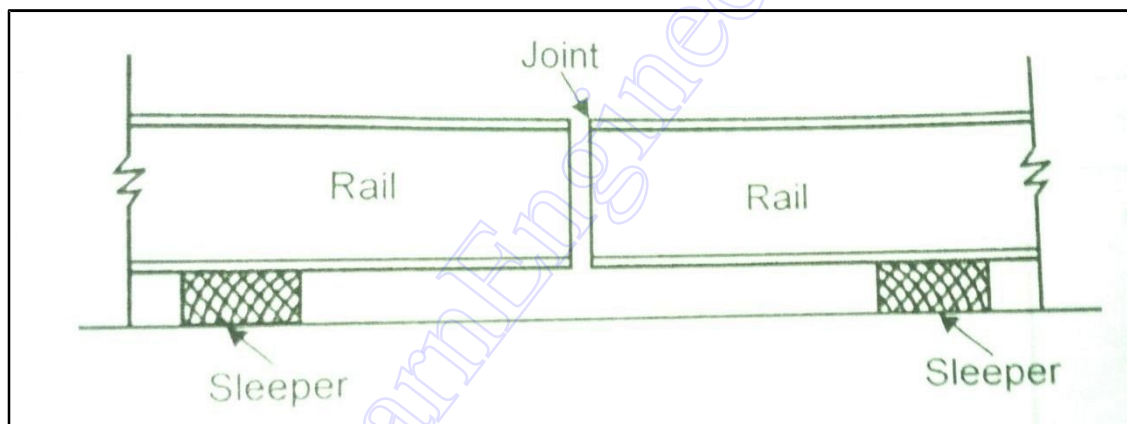

Supported joint:

When the sleeper is placed exactly below the rail joint, it is known as supported joint.

These types of joints are not used at present.

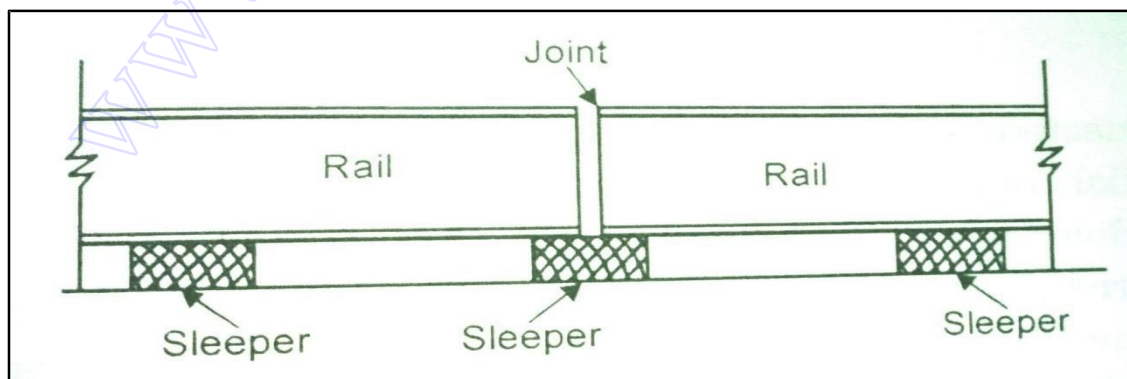



Bridge joint:

When a suspended joint is bridged by a metal piece so as to connect the ends of the two rails and thereby preventing bending stress in the rail.

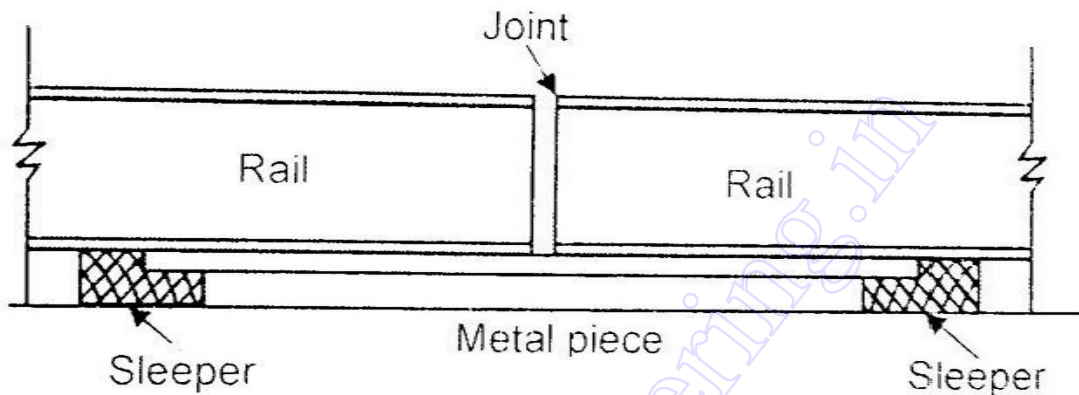

4. Briefly explain the modern methods of surveys for track alignment. (Apr / May 2011) (8 mark)

Introduction:

Railway planning needs precious and cost effective methods of surveying. Modern methods like GIS, GPS etc were incorporated for effective surveying.

Different features :

- Survey of India map
- Village map
- Ward / block map
- Updating of map

Application of modern survey equipments for railway alignment surveying:

i. Global positioning system (GPS)

It measures co-ordinates of any point anywhere on the globe. This survey is possible at any weather conditions and a minimum of 24 no. of satellites at a distance of 10,000 km from earth's surface will be involved in surveying.

ii. Electronic distance meter (EDM)

EDM works on electromagnetic waves travel between the given origin and



destination. Typical EDM can measure a distance upto 5 – 10 km.

iii. Total station (TS)

It works on same procedure of EDM but it also measures the angle along with the distance. It is more accurate than EDM and has a least count of one second. Also reduces human interventions and measurements.

iv. Geographical Information systems (GIS)

It is a system of software and hardware. It is used to prepare highway, railway alignment. Techniques of GIS such as buffering and network analysis are widely applied in highway and railway planning.

v. Remote sensing data products

- a. Aerial photos
- b. Satellite imageries
- c. High resolution satellite imageries

Merits of modern methods:

- Rapid process of surveying
- Optimum resource planning
- Acceleration construction programming
- More accuracy
- Less time consuming
- Updating and correction of old map will be much easier.

Demerits of modern methods:

- Applies only for skilled workers
- Exact boundaries cannot be determined on satellite imageries
- Procurement of equipment/systems such as GPS, EDM, GIS, Stereo potters are cost intensive.



5. Determine all the elements of a turnout, when the following data is given:

Heel divergence = 13.65 cm

Angle of switch = 1 34' 27"

Gauge = 1.676 m

Number of crossing = 8.5

(Nov / Dec 2012)

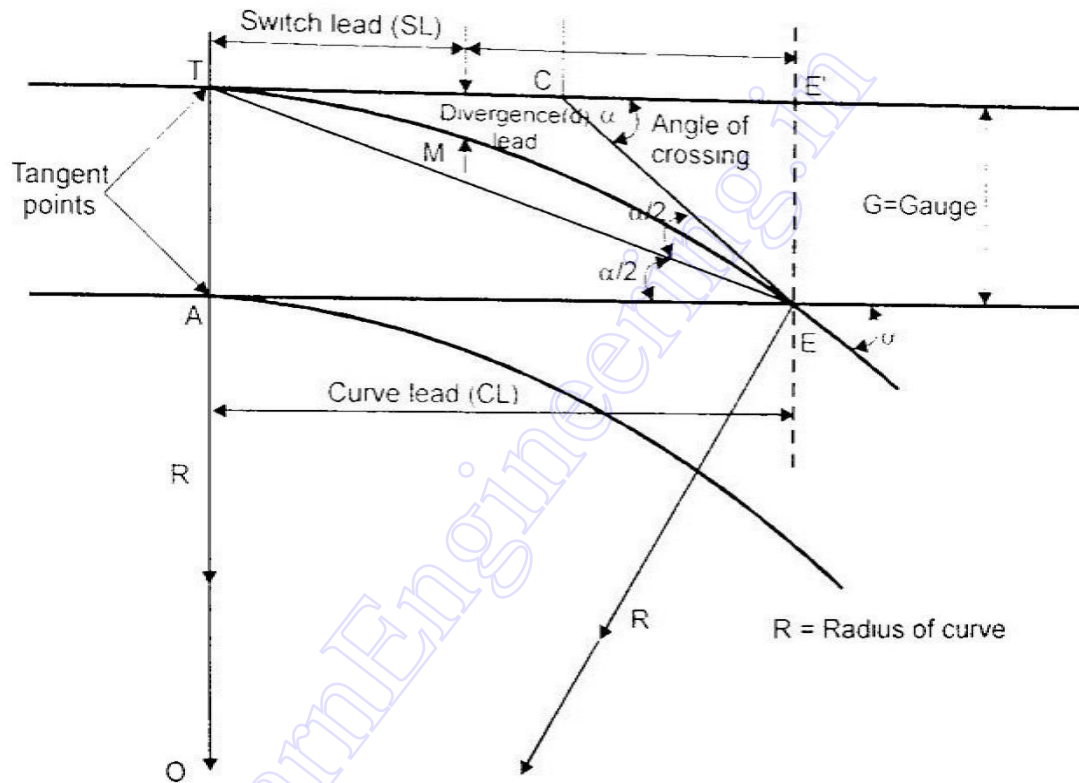

Solution:

Number of crossing = 8.5

Gauge of track (G) = AT = EE' = 1.676 m

Angle of crossing (α) = $\cot^{-1}(8.5)$

(i) Curve head, CL

$$\begin{aligned} CL &= 2 GN \\ &= 2 \times 1.676 \times 8.5 \\ &= 28.49 \text{ m} \end{aligned}$$

Heel divergence (d) = 13.65 m

$$= 0.1365 \text{ m}$$

(iii) Radius of curve (R)



$$\begin{aligned}
 R &= 1.54 + 24N^2 \\
 &= 1.54 + 248.52 \\
 &= \mathbf{1735.54 \text{ m}}
 \end{aligned}$$

(iv) Switch Lead (SL)

$$\begin{aligned}
 SL &= \sqrt{2 \times 1735.54 - 0.137^2} \\
 &= \mathbf{58.91}
 \end{aligned}$$

(v) Lead Crossing (L)

$$\begin{aligned}
 L &= G \cot \alpha/2 - \sqrt{2Rd} - d^2 \\
 &= \mathbf{1.676 \times \cot \alpha/2 - 58.91}
 \end{aligned}$$

6. Illustrate with neat sketches a right hand or a left hand turn out, points and crossings and explain their working principles. (Apr / May 2011)

Turnout:

A turnout is a complete set of points and crossings along with lead rails which enables a rolling stock to be diverted from one track to another.

Important components:

- A pair of points or switches
- A pair of stock rail
- Check rail
- Lead rail
- Stretcher bar
- Crossings or 'V' piece
- Wing rail

Points or Switches:

Types:

Stub switch: No separate tongue rail is provided

Split switch: Loose heal type

Fixed heal type

Constituents:

- A pair of stock rails AB and CD
- A pair of tongue rails PQ and RS



- A pair of heel blocks
- A gauge tie plate to ensure correct gauge

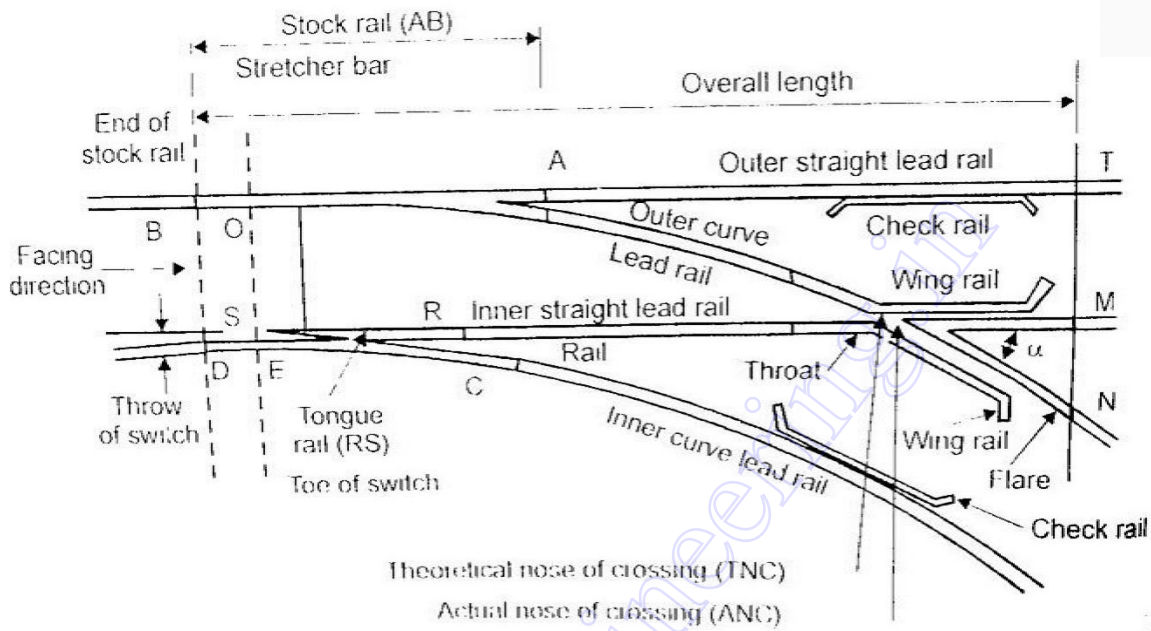

Components of a right hand turnout

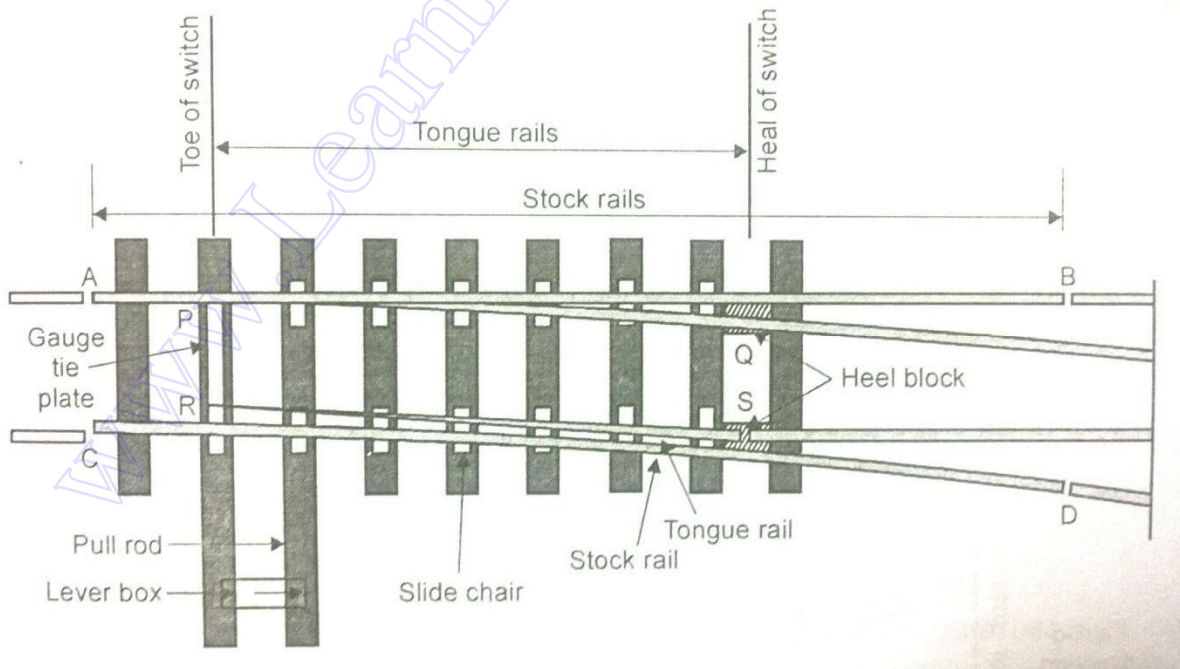

Details of a switch

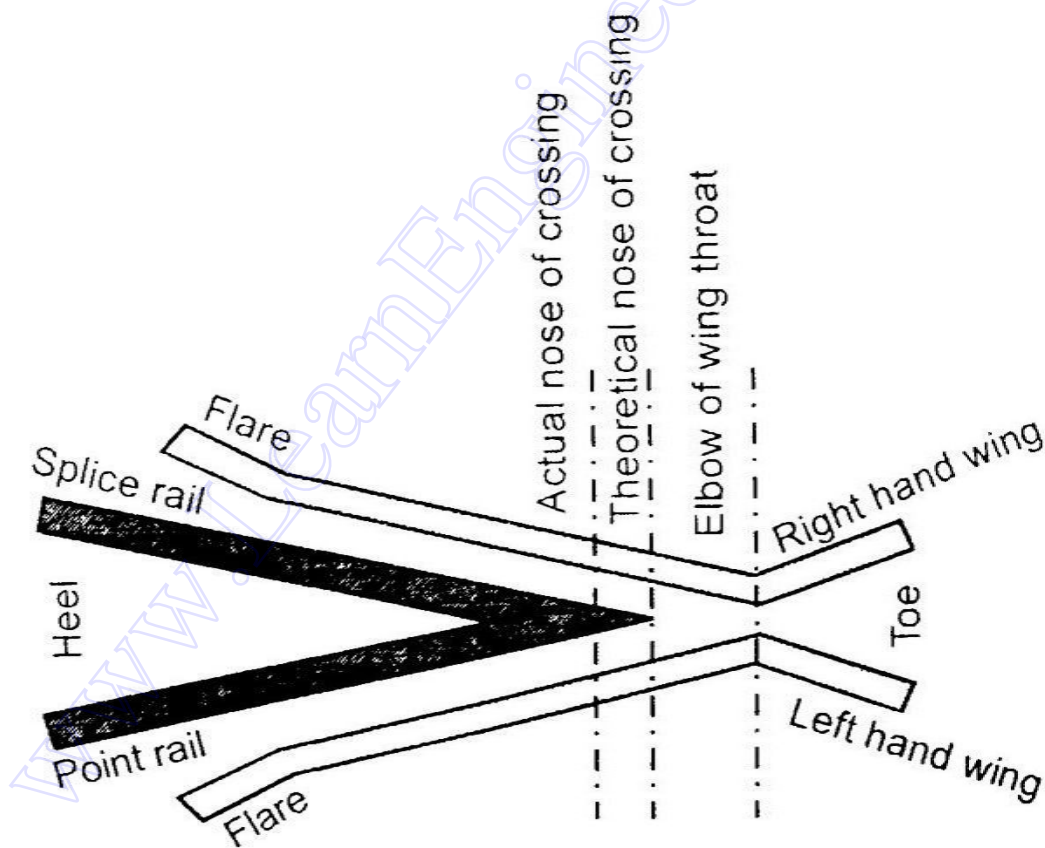
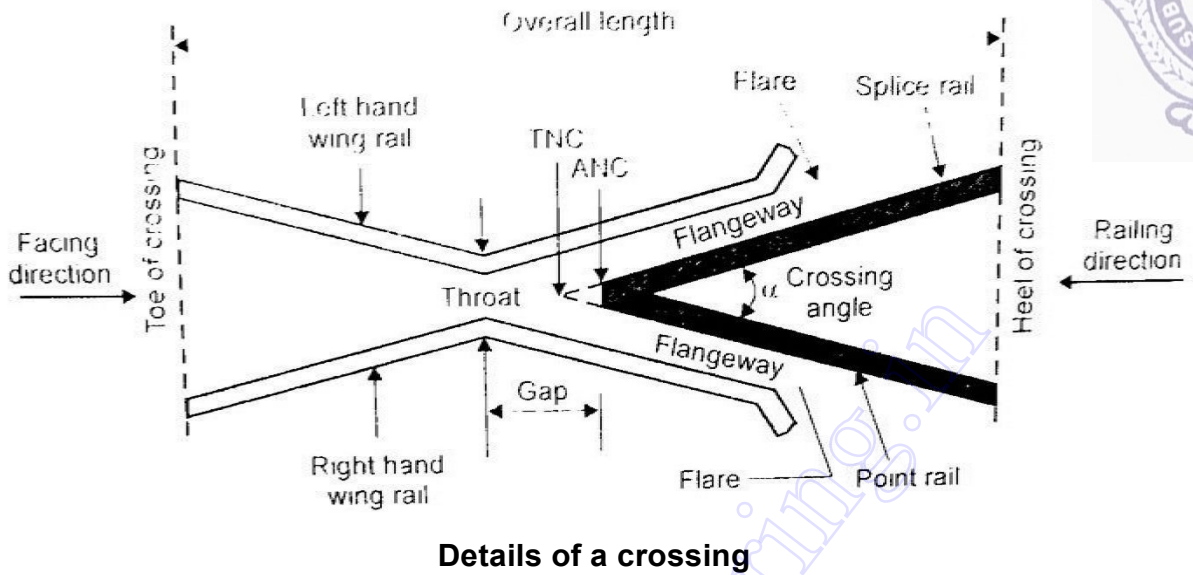

Crossings:

Definition and purpose: A Crossing is a device, inserted at a location where two rails



cross each other. It enables the wheel flanges of rails to pass from one track to another track. Flanged wheels jump over the gap provided from the throat to the nose of the crossing.

Constituents: A crossing consists of

- Two rails called point and splice rail which are machined to form nose. The point rail ends at the nose.
- A left hand and right hand wing rails form a throat and diverging again on either side of nose.
- A pair of check rails to guide and to provide a path for wheel flanges.

Working principle of points and crossings:

- a. **Split switch:** It consists of tongue rail and a stock rail with fastenings. A pair of them constitutes a set of points. The points by their operation can divert traffic moving in facing direction from one track to another track.
- b. **Crossing device:** A crossing is a device introduced at the intersection of two running rails to permit the wheel flanges, moving along one to pass across the other. The crossing should be rigid enough to withstand against severe vibrations.
- c. **Check rail:** A pair of check rails are provided to guide the wheel flanges and to route a path for them by which the sideways movement is prevented.

7. Explain super elevation giving its relationship with gauge, speed and radius of the curve. (Nov / Dec 2014) (8 mark)

Superelevation:

Superelevation or cant is the difference in height between the outer and inner rail on a curve. This is provided in the field by a gradual lifting of the outer rail while maintaining the inner rail in its original level.

Functions:

- i. To minimize the wear and tear of the rails and rolling stock
- ii. To have better load distribution on both the rails
- iii. To modify the effect of lateral forces



iv. To provide a comfortable journey to the passengers

Equilibrium superelevation:

While vehicle on curves experience an outward centrifugal force due to the radial acceleration. The centrifugal force is given as

$$F = m (V^2 / R) = (W / g) (V^2 / R)$$

Where F = centrifugal force (tonnes)

W = weight of the vehicle (tonnes)

V = speed (m/s)

g = acceleration due to gravity (m/sec²)

R = radius of the curve (m)

In order to counteract the effect of centrifugal force, the outer rail of the curve is raised with respect to the inner rail by an amount equal to the superelevation.

Let θ be the angle that the inclined plane (line joining the top inner and outer rails) make with the horizontal. Then

$$\text{Tan } \theta = \frac{\text{Superelevation}}{\text{Gauge}} = \frac{e}{G}$$

Also
$$\text{Tan } \theta = \frac{\text{Centrifugal force}}{\text{Weight}} = \frac{F}{W}$$

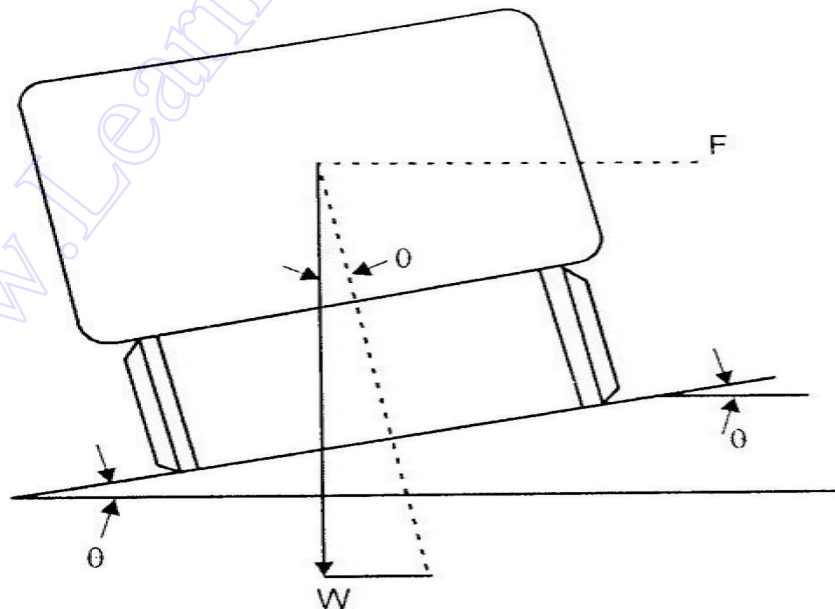

Equilibrium Superelevation



Equating the values of $\tan \phi$

$$\frac{e}{G} = \frac{F}{W}$$

Or
$$e = F \times \frac{G}{W} = \frac{W}{g} \times \frac{V^2}{R} \times \frac{G}{W}$$

i.e.,
$$e = \frac{GV}{gR}$$

where, e = superelevation
 G = gauge (mm)
 = gauge length + width of rail heads

This is equal to

1750 for BG tracks

1058 for MG tracks

8. What do you understand by “cant deficiency”? (Apr / May 2015) (8 mark)

Cant deficiency:

When a train moves around a curve at a speed more than the equilibrium speed, then deficiency in cant occurs. Thus the cant deficiency is the difference between the theoretical cant required for high speed and the actual cant provided.

Cant excess:

When a train moves around a curve at speed less than the equilibrium speed then excess in cant occurs. Thus cant excess is the difference between the actual cant provided and the theoretical cant required.

Cant gradient:

Cant gradient and deficiency gradient express the increase or decrease in the cant or the deficiency of the cant in a given length of transition. For example, a gradient of 1 in 1000 represents that a cant deficiency of cant of 1 mm is attained or lost in every 1000 mm of transition length.

The maximum values of cant deficiency prescribed for Indian railways are given below:

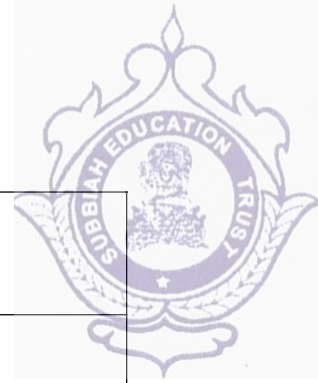

Gauge	Group	Normal cant deficiency (mm)	Remark
BG	A and B	75	For BG group A & B routes: 100 mm cant deficiency permitted only for nominate stock and routes with the approval of CL
BG	C, D and E	75	
MG	-	50	
NG	-	40	

9. What is meant by gradient and enumerate the various types of gradient with all the details. (Nov / Dec 2008) (May / June 2012)

Any departure of the track from the level is known as gradient or gradient. Reason for the usage in railway track

1. To provide a uniform rate of rise or fall as far as possible
2. To reach the various stations located at different elevation
3. To reduce the cost of the earthwork.

Types of gradient

1. Ruling gradient
2. Momentum gradient
3. Pusher or helper gradient
4. Gradient at Station Yard

1. Ruling gradient

The ruling gradient on a section may be defined as a gradient which determines the maximum load that the engine can haul on the section.

In determination the ruling of the section may be defined as, it will not only be that the survey of the gradient that will come into play but also the length of the gradient and its position

In plain terrain = 1 in 150 to 1 in 200

In hilly terrain = 1 in 100 to 1 in 150



2. Momentum gradient

The rising gradient is called as momentum gradient and in such cases a steeper grade than the ruling grade can be adopted.

The gradient on the section which through more severe than the ruling gradient, do not determine the maximum load of the terrain but on account of their favorable position on the track.

For example in valleys, a falling gradient is usually followed by a rising gradient

3. Pusher or helper gradient

If the grade concentrated in a Specific section such as mountainous section. Instead of limiting the terrain load.

It may operationally easy or even economical to run the terrain on the basis of load that can carry in the remaining portion of the track and arrange for an assisting engine is called pusher or helper gradient.

4. Gradient in Station Yard

The gradient at Station Yard has to be sufficiently low due to the following reason

- (a) To prevent the movement of Standing vehicle on the track due to the effect of the gravity
- (b) To prevent the additional resistance due to the grade on the Standing Vehicle

Grade Compensation

In order to avoid the resistance beyond the allowable limit, the gradients are reduced on curves. Then the reduction can be named as Grade compensation

9. Enumerate the concept of an grade compensation and also explain the basic formulas used in grade compensation. (Nov / Dec 2012) (April / May 2011) (Nov / Dec 2007)

Due to the rigidity of the Wheel base, it is sometimes found on the Curve that the rails are tilted outwards so that the actual gauge is more than the theoretical value

Wheel Base is defines as the distance between the adjoining Axes which are held in a rigid frames. The maximum value of the rigid wheel base in India on B.G Yard and M.G yard are 610cm and 48 cm respectively. To prevent the tendency the gauge of



the track is sometimes widened on Sharpe Curves. The amount of widening of gauges depending upon the radius of the Curve, Gauge and rigid Wheel base on the vehicle.

The various formulas are Available for finding out the Extra Width of the gauge required on Curves. Incase, the Extra width should not Exceed 25mm on 1676mm and 1435mm gauges and 16mm on the M.G. Some rules are mentioned as follows

Rule 1:

$$D = (B+L^2) * 125 / R$$

Where

D= Extra width of the gauge in mm

B=Rigid Wheel base in mm

L=Lap of the Curve

R=Radius of the Curve

Now, the value of lap of flange in mm is obtained by the Following equation

$$L = 2 [(D+H)*h]^{1/2}$$

Where

D= Diameter of the Wheels in mm

H=Depth of the Wheel flange below in mm

Rule 2:

Multiple half of the Wheel base by lap of the flange and when divide this result by the radius of the curvature plus half the gauge

Multiple the gradient by 3000 and the result will be the Extra required in mm. The Wheel base, lab of flange, radius of the curvature and the gauge to be Expressed in meters

Rule 3:

The gauge was widened for a curve of over 3 degrees. But at present the Gauge is not widened up to the curvature of 4.5 degree on the B.G Yard and 5-9 to on M.G in USA the practice is not to widen the gauge at the rate of 3mm for every 2 degrees of curvature up to a maximum of 19m.